



COMPANY INC

solving your wire stitching needs for 125 years...

Machine Serial Number : _____

Head Serial Numbers : _____

Date Purchased : _____

Model M27 Stitcher

OPERATION AND MAINTENANCE MANUAL

M27-AST Stitcher.....115V and 60HZ

M27-BST Stitcher.....230V and 50HZ

M27G20-AST Stitcher.....115V and 60HZ

M27G20-BST Stitcher.....230V and 50HZ

Before using this Stitcher, all operators must study this manual and follow the safety warnings and instructions. Keep these instructions with the M27 Stitcher for future reference. If you have any questions, contact your local DeLuxe Stitcher Graphic Arts Representative or Distributor.

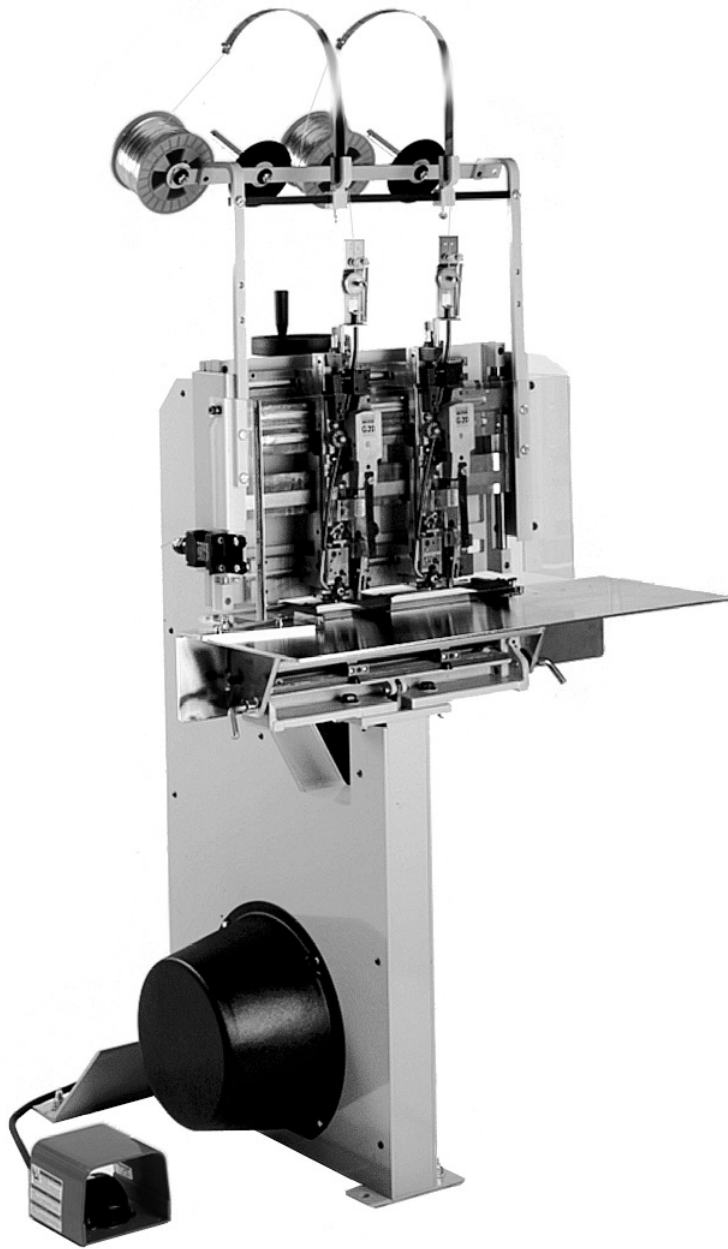

*THANK YOU FOR CHOOSING THE
MODEL M27
FOR YOUR BINDING NEEDS*

WARNING!

Model M27 Stitchers

Operators and others in the work area should always wear safety glasses to prevent serious eye injury from fasteners and flying debris when loading, operating, or unloading this machine.

Do not operate this stitcher without all guards in place. The stitcher will not operate without the front guard closed properly. Do not modify the guards in any way. Always disconnect the power supply before removing any guards for servicing.

Never operate the machine with wire feeding through the head unless there is stock above the clinchers, otherwise serious damage may result.

Always turn power off when making adjustments. Always disconnect the power supply before any disassembly work.

Table of Contents

Introduction	4
Assembly	7
Belt Guard Removal and Assembly	8
Cycling Machine Manually	9
Operating Adjustments	10
Adjusting the Machine for Thickness of Work	10
Recommended Wire Sizes	11
Adjustments and Settings.....	13
Adjusting the Clincher Points	13
Troubleshooting.....	15
Maintenance	16
Lubrication	16
Ordering and Replacing Spare Parts	17
Mounting & Removing the Head	18
Clutch-Brake Maintenance	19
Assembly Drawings	24
Part Number / Description Cross-Reference	34
Declaration of Conformity.....	36
Registration Card	37
Warranty	39

Introduction

The DeLuxe M27 Stitcher Machine is a multi-head stitcher designed to accommodate both light and heavy-duty work, stitch both flat and saddle, and is recognized for being the highest capacity multiple head stitcher due to its ability to reliably stitch any thickness of stock from 2 sheets to 3/4" (20mm).

The M27 accommodates both the Traditional Style 18D Head and the Side-Feed Style G20 Stitcher Head. Up to four heads can be mounted along the machine's 17" (43cm) rail at a maximum distance of 13" (33cm) between Heads. Because either Head can be used the recommended wire sizes for the M27 are: 20 to 28 gauge round wire and 19x21-1/2, 20x24 and 21 x25 flat wire. The M27 comes standard with two (2) Stitcher Heads but replacement Heads can be added when an application requires it. When ordering extra Heads, add the wire and crown size to the Head part number. For example: G20MHD20241/2.

18001MHD M27AST and M27BST
G20MHD M27G20AST and M27G20 BST

The M27 is easily adjusted from saddle work to flat work by tilting the 12" (30cm) x 33" (84cm) work table. An adjustable work guide and adjustable work stops are easily attached to the work table and provide for accurate registering of flat work for uniformly spacing the staples. In addition a work table extension is provided to accommodate larger sizes of work to be stitched.

The M27 is foot-switch operated and belt driven by a 3/4 HP motor, making possible operating speeds up to 150 stitches per minute. The motor is mounted on an adjustable bracket which can be raised or lowered to adjust driving belt tension. The driving mechanism is thoroughly shielded, preventing the possibility of personal injury.

The M27 has a 14" (36cm) throat depth for either flat or saddle stitching. The work table is approximately 35" (89cm) above the floor and there is approximately 1" (25mm) clearance between the top of the work to be stitched and the protective guarding around the stitcher head.

The M27 weighs 470 lbs. (213 kgs) net with two (2) Heads and the shipping weight is approximately 570 lbs. (259 kgs). With the table installed, the M27 requires about 32" (81cm) x 35" (89cm) of floor space.

Because of the length of the work table, the M27 must be secured to the floor to meet CE stability requirements. Sound level readings at the normal operator position are approximately 70 dB.

Specifications

Weight

Shipping Weight	580 lbs (263 kg)
18D Stitcher Head (each)	18 lbs. (8 kgs)
G20 Stitcher Head (each)	22 lbs. (10 kgs)
Wire Spool	5 lbs. (2.3 kgs) or 10lbs. (4.6 kgs) optional
Foot Switch	4.5 lbs. (2.0 kgs)
Table	30 lbs. (13.6 kgs)

Shipping Dimensions

Height	65.0" (165 cm)
Width	
With Tables	35" (89 cm)
Without Tables	16" (41 cm)
Depth	30" (76 cm)

Stitching Capacity	Two Sheets to 3/4" (20 mm) (with G20 Heads)
 at 20# paper stock (75 grams/meter ²)
 Two Sheets to 9/16" (14 mm) (with 18D Heads)
 at 20# paper stock (75 grams/meter ²)

Wire Types 20-28 Round, 19x21½, 20x24 and 21x25 Flat
-------------------	---

Throat Depth

Flat or Saddle	14" (36 cm)
----------------	-------------

Side Stops 6-1/4 - 28-5/16" (16 cm-72 cm)
-------------------	--------------------------------------

Power Requirements

M27-AST	115VAC 60 Hz
M27-BST	230VAC 50 Hz

Minimum Recommended Circuit Capacity

M27-AST	11.8 A
M27-BST	7.8 A

Installation

Pre-Inspection

Carefully inspect the condition of the shipping container before unpacking your M27 Stitcher. If the container is broken, damaged or has been tipped over and there is evidence that the machine may be damaged, immediately notify the carrier who delivered the machine and the DeLuxe Stitcher Graphic Arts Representative from whom the M27 was purchased.

Inspection

As you carefully unpack the machine, check to make sure all components were delivered and are in good working order. Refer to **Figure 1** in this manual for reference to the following pieces:

- M27 Manual
- Complete Work Table Assembly (17145FA) with a Right-Hand Side Paper Guide (A1178), a Left-Hand Side Paper Guide (A1185), Work Guide Screws (63) Back Gauge Bar Assembly (17161A), Back Stop Gauge (G30164A) and Plate (17149).
- Pivot Bar (17146) and set of Table Lock Pins (16148)
- Assembled Spool Bar (17280) and Guide Spring Bar (17289) with Brackets (17282)
- Wire Spool (for each head shipped), along with a Spool Stud (7693), Plastic Washer (M11009), Tension Spring (7690), Set Collar (7691) with Thumb Screw (P2731), 9/16 Washer (PG10271), Spool Washer (2245), 3/8 Washer (PW38) and Hex Nut (HN3816)
- Wire Guide Spring (18150A) for each Stitcher Head shipped.
- Driver Release Pin (5160) for each 18D Head shipped.
- Wire Guide Spring Plate Assembly (G20278AA), a set of 2.0, 2.5, 3.0 and 5 mm Hex Key Wrenches (G20361, G20360, G20362 and G20374) and an Open End Wrench (G20364) for each G20 Head shipped.
- Upper Wire Tube (G20581) for each G20 Head shipped.
- Stitch Samples

Pre-Installation

Please take a few moments to fill out the registration card located on page 42 prior to beginning installation.

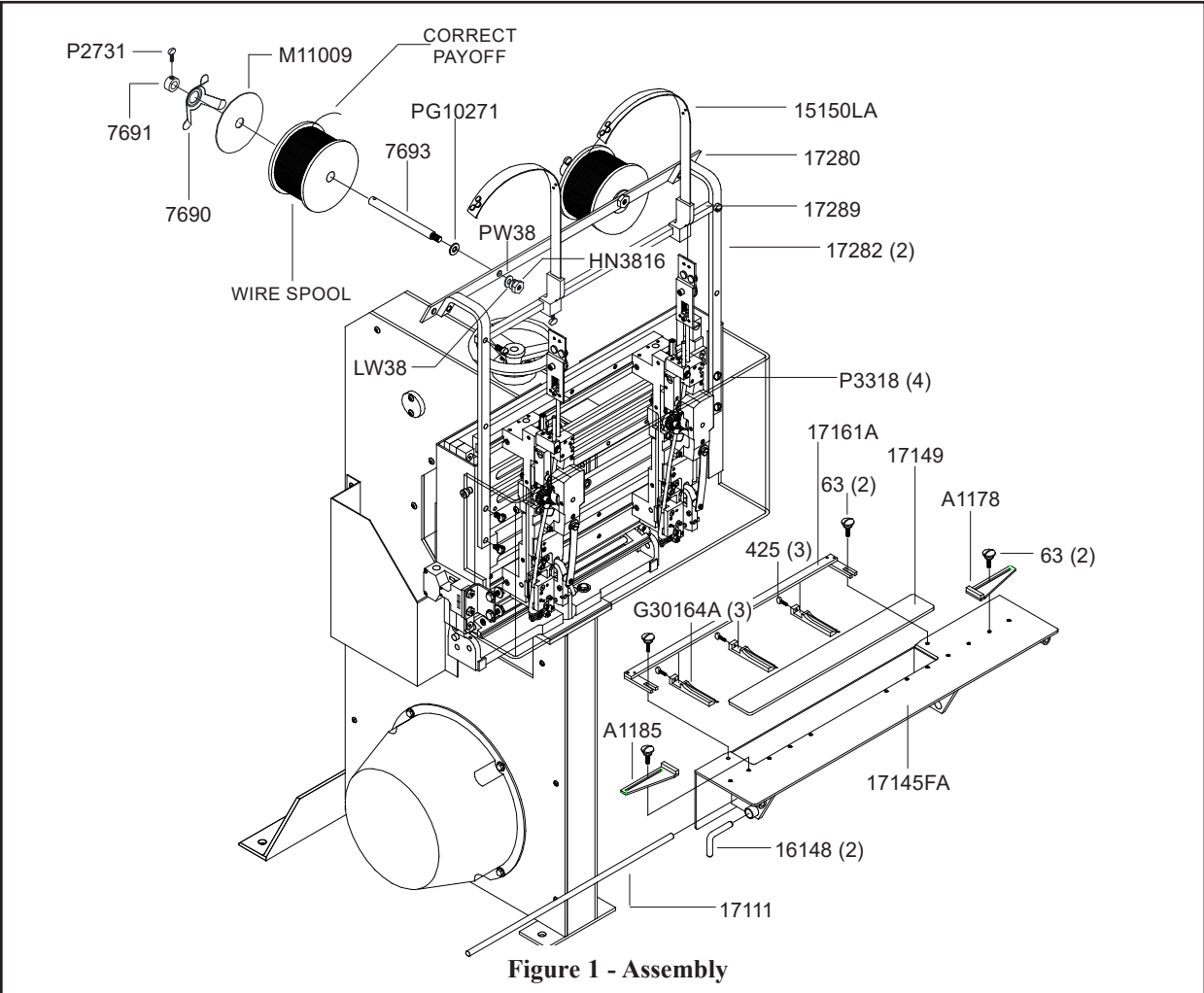

Figure 1 - Assembly

! WARNING

Always disconnect the power supply before making any adjustments or servicing the stitcher.

Assembly (Figure 1)

Some assembly is required upon delivery of the M27 Stitcher. You will need a flat screwdriver and a 9/16 open end wrench. Remove the packing materials from around the M27 and all contents from the shipping boxes. Mount the Spool Bar Brackets (17282), which are already assembled with the Spool Bar (17280) and the Wire Guide Spring Bracket Bar (17289), to the Stitcher with four (4) Screws 5/16-18x3/4 (P3318). Locate the Spool Stud (7693) and remove the Hex Nut (HN3816), Washer (PW38) and Lock Washer (LW38) from the one end. Insert the threaded end of the Spool Stud into Spool Bar so that it is lined up with the stitcher head already mounted to the Machine. Replace the Washers and Hex Nut. Loosen the Thumb Screw (P2731) in the Set Collar (7691) to remove it and the Tension Spring

(7690) from the Spool Stud. Slide the Wire Spool over the Spool Stud, making sure that the Flat Washer (PG10271) is between the Spool and the Wire Spool Bracket. **Also verify that the wire payoff is identical to the payoff in Figure 1; from left to right.** Improper wire payoff will result in poor stitching. Slip the Plastic Washer (M11009) over the Spool Stud and replace the Tension Spring and Set Collar. Apply slight pressure on the Set Collar, pre-loading the Tension Spring, then tighten the Thumb Screw in the Set Collar until secured in position. A properly set Tension Spring will cause the Wire Guide Spring (15150A or 18150A) to flex but not actually hit the wire spool. The Tension Spring is designed to prevent the Wire Spool from over-running and tangling the wire.

Remove the assemblies from the complete Work Table Assembly (17145FA): the Right-Hand Side Paper Guide (A1178), the Left-Hand Side Paper Guide (A1185), four (4) Work Guide Screws (63), the Back Gauge Bar Assembly (17161A), the Back Stop Gauge (G30164A) and the Plate (17149). Center the Table Assembly over the Clincher Rail of the machine and secure the Table with the two (2) Pins (16148). Once the Table is secured, insert the Pivot Rod (17146) through the Table and Clincher Rail. You may have to use a soft hammer to completely insert the Rod.

Note: Be sure to loosen the two (2) Set Screws (38) before attempting to insert the Pivot Rod.

Belt Guard Removal and Assembly (Figure 2)

The plastic Belt Guard (7676) must be removed before the M27 can be turned over manually. To remove the Belt Guard, remove the Retaining Screw (G30163) from the top of the Guard (on BST models only). Press on one side tab while prying out the locking face, at the top of the Guard. Next, pull down slightly on the top of the Guard to release the bottom tab. The Guard will now be free to lift off from around the Belt Guard (7675).

To reassemble, interlock the bottom tab and pull up slightly on the Guard to interlock the side tab, then squeeze the two halves of the Guard together to lock the remaining tab. Reassemble the retaining screw at the top of the Guard (on BST models only).

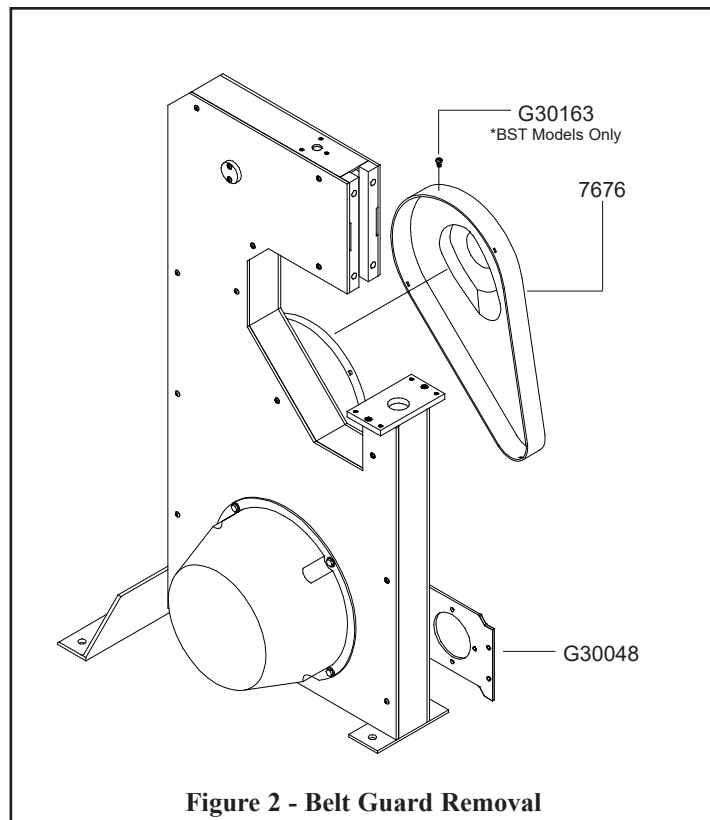

Figure 2 - Belt Guard Removal

Always disconnect the power supply before making any adjustments or servicing the stitcher.

! WARNING

Cycling Machine Manually / Adjusting the V-Belt (Figure 3)

To turn the machine manually, it is first necessary to disconnect the power and remove the Belt Guard (7676), see the section “Belt Guard Removal” on page 8. Locate the Actuator Assembly (850992) on the Wrap Spring Clutch (850673 or 850674) and push the Actuator so that it pivots away from the Control Collar Cam (850888), releasing the Brake Hub (850892). The machine will rotate one revolution when the Drive Pulley (7678) is turned manually in the direction of the arrow on the pulley.

To tighten the V-Belt (850730C) first loosen, but do not remove, the four (4) Hex Nuts (HN3816) on the Motor Mounting Plate (G30048). Use a screw driver as a lever between the stitcher’s frame and the Mounting Plate to move the Plate down slightly. Pressing on the Pulley (850732) may knock it out of position. Tighten the four (4) Hex Nuts again when the V-Belt is taut. The V-Belt should first be tightened after two to three weeks of use and then periodically after that.

Moisture, change in temperature as well as wear can affect the tightness of the Belt. Loose Belts can cause the Stitcher to stall and may damage the Belt permanently.

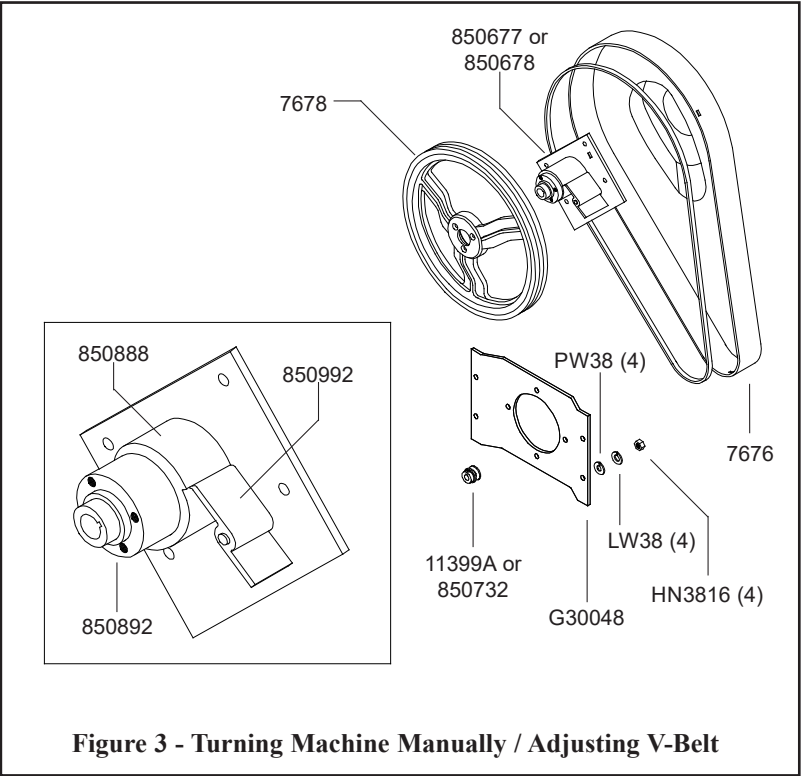

Figure 3 - Turning Machine Manually / Adjusting V-Belt

Operating Adjustments

The quality and quantity of work that can be stitched on the M27 is dependent upon the operator making the necessary operating adjustments as accurately as possible. The following information and instructions are provided so that the operator will clearly understand how to make the required operating adjustments.

Additional Operator's Manuals for the stitcher heads supported by the M27 Stitcher are included with the Stitcher itself. Please refer to these manuals for specific instruction and operating adjustments for the individual stitcher heads.

! WARNING

Failure to properly adjust for the compression will severely damage the stitcher.

Adjusting for Thickness of Work (Figure 4)

Unlock the Hand Wheel (G30128) by turning the Adjuster Crank Lock (G30158) on the Adjuster Crank Housing (G30099B) counter-clockwise. Turn the Hand Wheel clockwise until the Adjuster Spool (G30119) is raised sufficiently to allow a sample of work to be inserted between it and the lower Adjuster Stop (G30103). The thickness gauge is located on the right-hand side of the machine if you are looking from the front of the stitcher. With the work held flat in a horizontal position, turn the Hand Wheel counter-clockwise until the work is firmly clamped between the Adjuster Spool and the lower Adjuster Stop. Turn the Hand Wheel back clockwise just enough to allow the work to be withdrawn from the Adjuster Spool, then return the Hand Wheel to the setting at which the work was clamped.

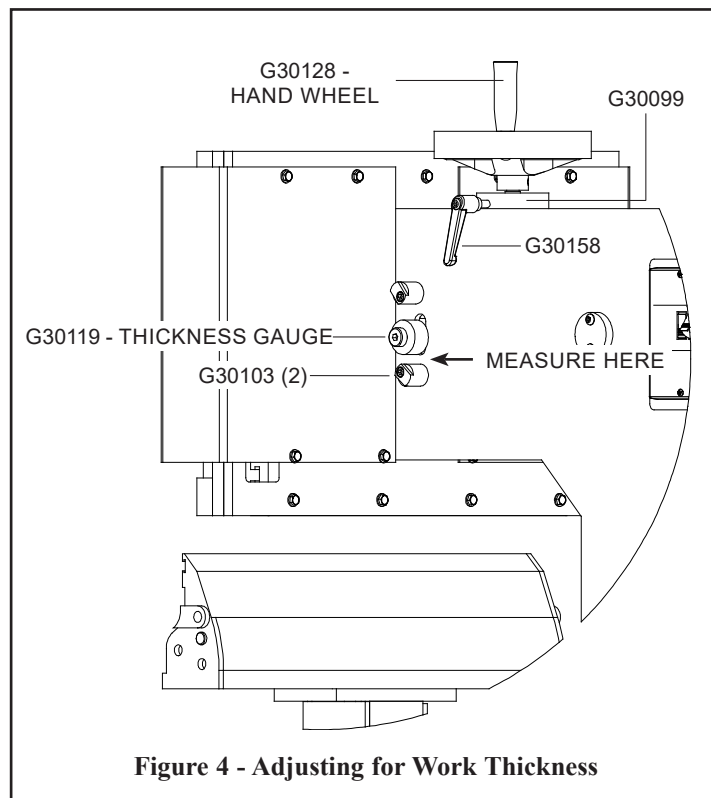

Figure 4 - Adjusting for Work Thickness

Anytime the thickness of work changes, a sample should be tested in the M27 so no serious damage is caused to the machine. If the machine is operated on work thicker than it is set to handle, damage will result and the stitcher machine will not operate properly.

If the machine is operated on work thicker than it is set to handle, damage will result. **! WARNING**

Recommended Wire Sizes (Figures 5 and 6)

The wire sizes that can be used on the M27 as well as recommended uses are listed below. Refer to the Operator’s Manual for the Stitcher Heads on your M27 when changing the existing wire size. Stitcher Heads are designed to accommodate a specific wire size. Wire gauges smaller than the specific size for the stitcher head can still be used, but the maximum capacity for that head will not be reached. For example, a 19x21-1/2 gauge wire head will function properly with 20x24 gauge wire but the stitching capacity for the Head will drop from 3/4” to 1/2”. Refer to **Figure 5**.

Two types of Clincher Points are provided with the heads on the M27. When running round wire, use the Clincher Points with part number **7257B**. When running flat wire, use the Clincher Points with part number **7024B**.

When stitching stock over 20# it is recommended that a high tensile wire be used, which is available in 21x25, 20x24 and 19x21-1/2 flat wire sizes. The high tensile wire may cause increased wear on certain parts. For any stock over 33# or coated stock it is recommended that 19x21-1/2 flat wire be used. Refer to **Figure 6** for a general overview of suggested wire sizes to use for specific stitch capacities.

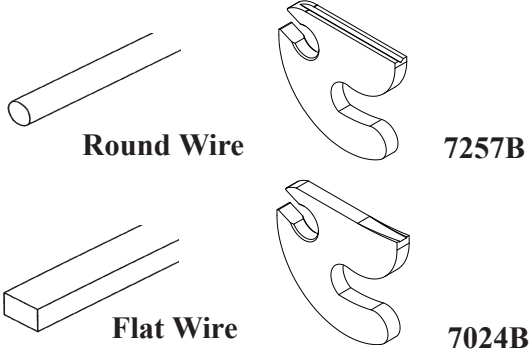

Stitcher Head Parts *	Wire Gauge Used	Max Capacity
20 Gauge	23 Round	2 Sheets to 1/8" (3 mm)
	22 Round	2 Sheets to 3/16" (5 mm)
	21 Round	2 Sheets to 1/4" (6 mm)
	20 Round	2 Sheets to 3/8" (10 mm)
	21x25 Flat	2 Sheets to 3/8" (10 mm)
	20x24 Flat	2 Sheets to 1/2" (13 mm)
24 Gauge	27 Round	2 Sheets to 1/32" (.75 mm)
	26 Round	2 Sheets to 1/16" (1.5 mm)
	25 Round	2 Sheets to 1/8" (3 mm)
	24 Round	2 Sheets to 1/4" (6 mm)
20x24 Gauge	25 Round	2 Sheets to 1/8" (3 mm)
	24 Round	2 Sheets to 3/16" (5 mm)
	21x25 Flat	2 Sheets to 3/8" (10 mm)
	20x25 Flat	2 Sheets to 1/2" (13 mm)
	20x24 Flat	2 Sheets to 5/8" (16 mm)
19x21-1/2 Gauge	25 Round	2 Sheets to 1/8" (3 mm)
	24 Round	2 Sheets to 3/16" (5 mm)
	23 Round	2 Sheets to 1/4" (6 mm)
	22 Round	2 Sheets to 5/16" (8 mm)
	21x25 Flat	2 Sheets to 3/8" (10 mm)
	20x25 Flat	2 Sheets to 3/8" (10 mm)
	20x24 Flat	2 Sheets to 1/2" (13 mm)
	19x21-1/2 Flat	3/8" to 3/4" (10 to 20 mm)

Figure 5 - Limited Stitching Capacities

* The 18D and G20 Heads can be equipped with these specific wire gauge parts.

Wire Gauge	Type of Work	20# Stock
28 Round	Light Flat or Saddle	2-5 Sheets
27 Round	Light Flat or Saddle	2-5 Sheets
26 Round	Light Flat or Saddle	2-10 Sheets
25 Round	Medium Flat or Saddle	2-40 Sheets
24 Round	Medium Flat or Saddle	2-60 Sheets
21 x 25 Flat	Heavy Flat Only	Over 50 Sheets 1/4"- 3/8" (6-10mm)
20 x 25 Flat	Heavy Flat Only	Over 50 Sheets 1/4"- 1/2" (6-13mm)
20 x 24 Flat	Heavy Flat Only	Over 50 Sheets 1/4"- 1/2" (6-13mm)
19 x 21 1/2 Flat	Heavy Flat Only	1/2"- 3/4" (13-20mm) and Heavy Paper

Figure 6 - Recommended Wire Sizes

Adjustments and Settings

Adjusting the Clinchers (Figures 7 and 8)

If the staples are not clinching properly the Clincher Points (7024B, 7024C or 7257B) will need to be adjusted within the Clincher Plate (7650A). Make sure the Table Assembly (17145FA) is in a flat work position. If it is not, remove the Plate (17149), loosen and remove the two (2) Pins (16148) securing the Table position and tilt the Table back. Return the two (2) Pins to secure the Table in the flat position. To check this, cycle the machine manually and stop it at the point of clincher activation. Loosen the Set Screw (UA1428.1) and rotate the Clincher Slide Adjustment Screw (18186), which raises or lowers the Clincher Slide (18182), and adjust the Clincher Points as needed. Rotating the Screw clockwise lowers the Points, while rotating the Screw counter-clockwise raises the Points. Tighten the Set Screw and replace the Work Table to its original position. **Figure 7** Complete the cycle of the machine and test a few stitches. Repeat the previous steps if necessary.

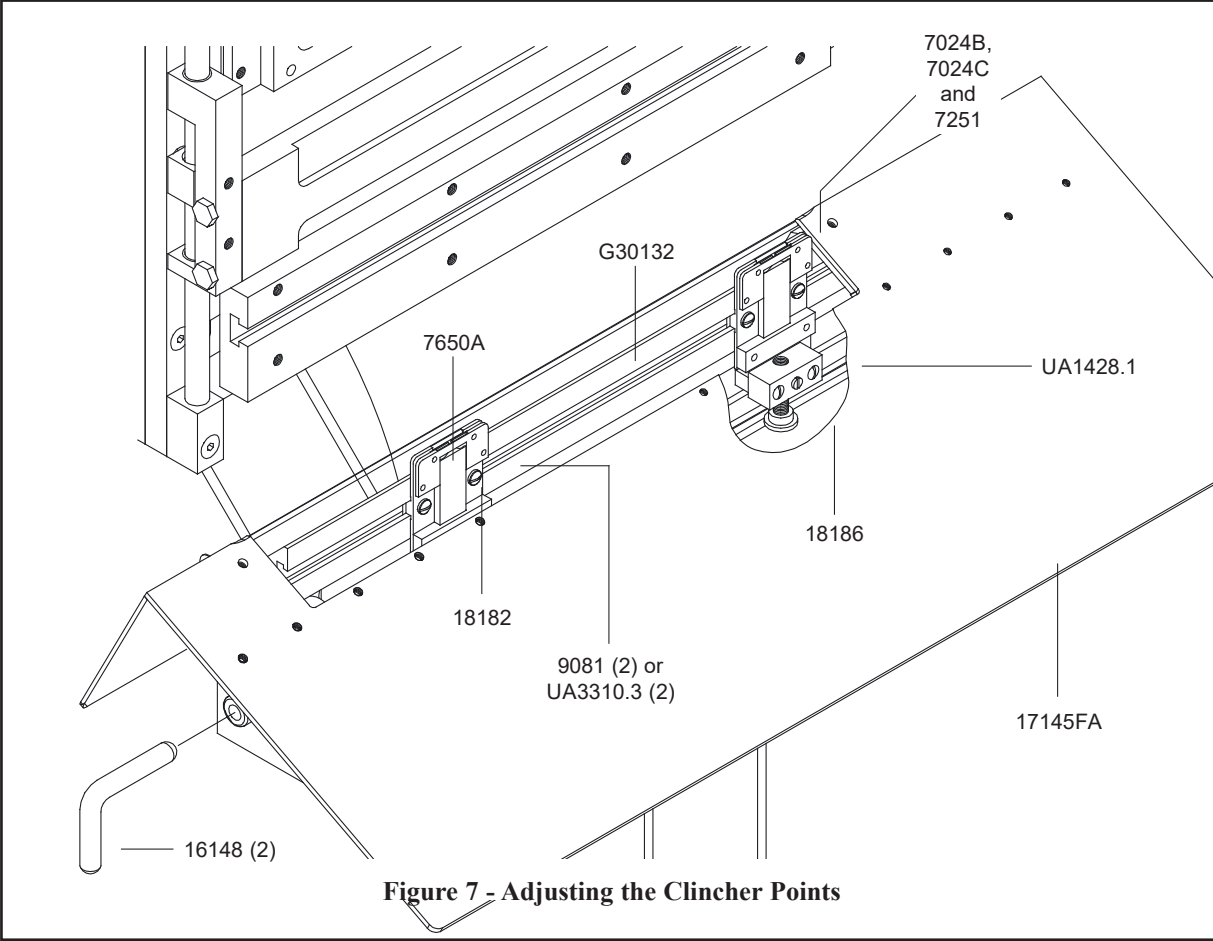

If the stitch clinches properly but the legs are angled away from its crown, the Clincher Plate may not be aligned with the Stitcher Head's Driver. Refer to both **Figure 7** and **Figure 8** and the following instructions for directions on centering the Clincher Points.

Loosen the two (2) Screws (UA3310.3 or 9081B) securing the Clincher Plate to the Retaining Plate in the M27's Clincher Rail. With wire threaded through the machine and the compression set to 1/8" turn the machine over manually, but stop as the staple begins to exit the Bender Bar. Move the Clincher Plate Assembly from side to side, until the Driver is centered above the Clincher Points. The legs of the staple should line up with the Clincher Points.

Although the front-to-back alignment is set at the factory, it can be adjusted one of two ways. For large adjustment, loosen the two (2) Screws (G30159) securing the Clincher Rail (G30132) to the M27 Frame. Using the same half-formed stitch for centering the Clincher Points, line the legs of the staple up with the Clincher Points from back to front. Tighten the Screws to secure the Clincher Rail in this position. Re-check the side-to-side adjustment after completing the front-to-back adjustments and then tighten the two (2) screws securing the Clincher Plate to the Retaining Plate in the Stitcher's Clincher Rail. Complete the machine's cycle and remove the formed staple so as to not jam the Clincher Points. For fine adjustments, refer to the Stitcher Head's Operation Manual. Specifically, refer to the section of the manual which highlights making adjustments to the Leveling Screws on the back of the Stitcher Head.

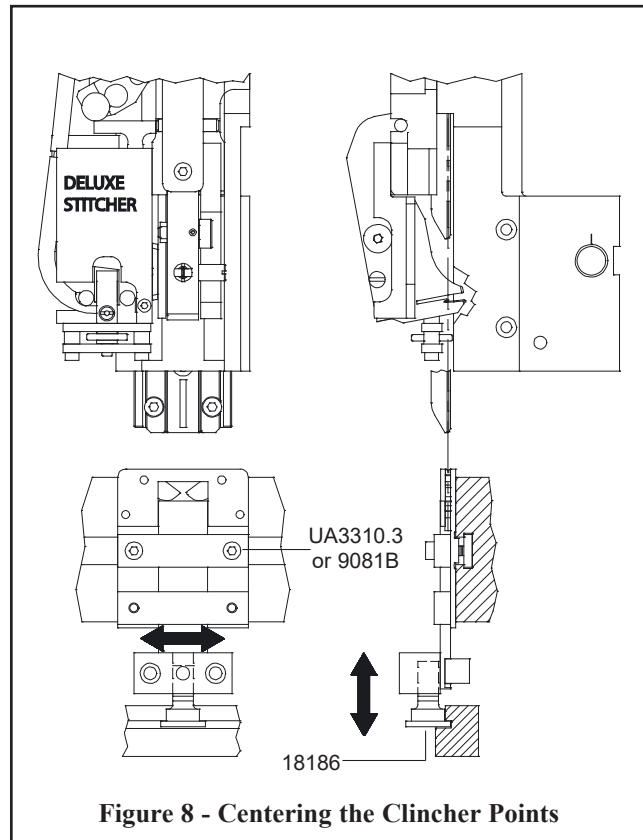

Figure 8 - Centering the Clincher Points

Troubleshooting

The following is a brief list of problems and solutions which should cover the majority of situations encountered when stitching with the M27. The quality and quantity of work that can be produced with the M27 Stitcher is dependent upon the operator making all adjustments as accurately as possible and carefully maintaining the machine. The cause of staple imperfections usually can be traced to inaccurate settings or normal wear of moving parts. In the event of problems of this nature occurring, the operator can, by referring to the following troubleshooting chart, quickly locate the solutions.

PROBLEM: The machine will not complete a cycle, under power or manually.

SOLUTION:

1. Make sure the compression setting is correct. If not turn the Hand Wheel (G30128) clockwise to raise the stitcher head.
2. If the V-Belt is too loose it must be tightened.
3. Make sure none of the Clutch Springs are broken and that the Clutch has not failed. If either are the case, replace the component or the entire assembly.

PROBLEM: The machine will not complete a cycle at all.

SOLUTION:

1. Make sure the Safety Interlock Switch (850308) on the Plastic Guard (G30135) is in complete contact with the Switch on the Left Guard Mount (G30133).

PROBLEM: Stitch quality is poor.

SOLUTION:

1. Refer to the Stitcher Head Operator's Manuals for more information.
2. Make sure that the wire is feeding straight from the Wire Spool and through the Stitcher Head.
3. Make sure the compression setting is correct.
4. Make sure the Clincher Plates are lined up with the Stitcher Head's Drivers, both side to side and front to back.
5. Make sure the Clincher Roller Bearing (G30041B), inside the Frame, is not worn or broken.
6. Make sure the Clincher Points are not set too high or too low.
7. Make sure the left leg of the stitch is same length as the right leg.

PROBLEM: Wire is dropped before it can be formed, drawn in inconsistent lengths or is jamming.

SOLUTION:

1. Refer to the Stitcher Head Operator's Manuals for more information.
2. Make sure that the wire is feeding straight from the Wire Spool and through the Stitcher Head.
3. Check for worn parts on both the Stitcher Head and on the M27 itself.
4. Make sure the Clincher Points are clear of debris and paper build-up.
5. Make sure the Clutch is set to stop 1/8" prior to top dead center at the end of a cycle.

Maintenance

Lubrication (Figure 9)

Your M27 Machine has been fully lubricated at the factory, but regular preventative maintenance will result in superior performance and a longer life of the machine. Machines that are in constant use should be lubricated weekly where as machines that are only operated periodically should be lubricated just prior to use. Usually only a drop of oil is required at each lubrication point. Care must be taken that those parts of the machine that contact work remain free from oil. Refer to the Stitcher Head Operator's Manuals for more information on the lubrication needs for the individual Stitcher Head on the M27 Stitcher.

Lubricate regularly instead of excessively.

Excessive oiling will result in work becoming oil-spotted. After lubricating the machine, wipe off any excess oil. Use one drop of any standard S.A.E #10 oil in the following lubrication points:

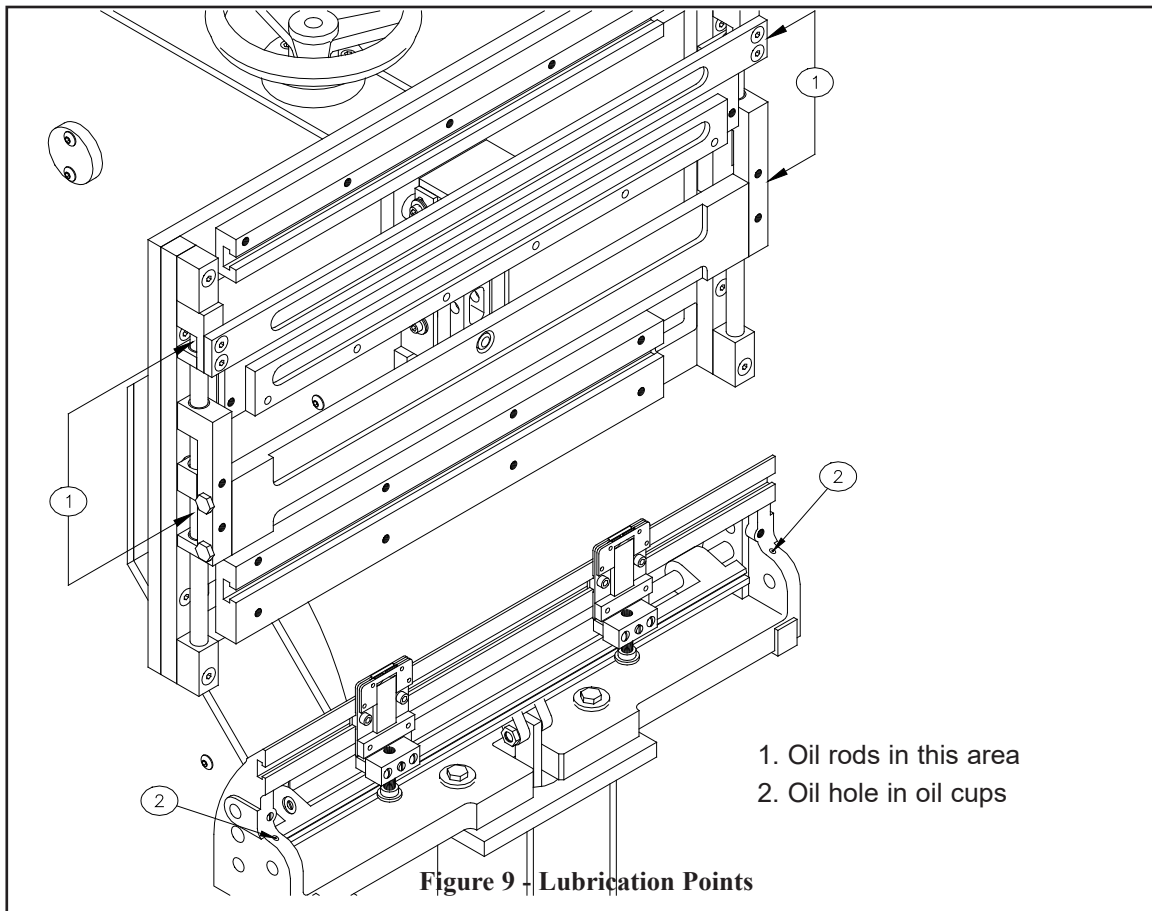

- the two (2) Slider Guide Rods (G30085) by the Adjuster Rail and by the Bender Rail Assembly
- the two (2) oil holes in the Clincher Rail (G30132)
- the lubrication points for the individual Stitcher Heads.

High friction areas should be lubricated with Red E-Lube Grease or any other Lithium-based grease once a year to prevent the areas from drying out. Remove the Screws (UA4810.5), securing the Left Side Cover Plate (G30002) to expose the internal assemblies. Apply Grease in the following areas:

- the Bender Cam Assembly (G30066A)
- the Crank Shaft Assembly (G30007A)

Ordering Spare Parts

In time, you may need to replace some parts of the M27 Stitcher Machine. To do this locate the DeLuxe Stitcher part number in one of the following diagrams and contact your Graphic Arts Representative to order the replacement by part number, description and quantity.

Always disconnect the power supply before making any adjustments or servicing the stitcher.

! WARNING

Replacing Spare Parts

The operator should periodically inspect all moving parts for signs of wear and when required, replace those worn parts. For a complete list of common stitcher head wear parts, refer to the Operator's Manual for the specific Head. Some of these parts are two-sided so that when the cutting or gripping surfaces show signs of wear, their position can be reversed to provide a new working surface, which lengthens the life of the part.

Mounting & Removing Heads

The M27 Stitcher Machine can accommodate up to four (4) Stitcher Heads. The time may come when additional Heads have to be added or removed from the stitcher. The following are guidelines for mounting and removing both an 18D and a G20 Stitcher Head to or from the M27.

To mount a Stitcher Head on the M27: Slip one (1) Bonnet Clamp Block (G20501 or 9002) into the Lower Bonnet Rail (G30106) and one (1) into the Upper Bonnet Rail (G30107) of the M27 Stitcher, approximately where the Head will be mounted. Align the Bonnet Clamp Eccentrics (G20524) or Handles (18005A) in the Stitcher Head with the Blocks on the Machine, starting with the bottom of the Stitcher Head. Tighten the Eccentric or Handle on the bottom slightly to hold the Head in position.

While continuing to support the top of the Stitcher Head, align the Bender Slide with the Bender Rail Assembly and tighten the Eccentric or Handle at the bottom of the Head a little more. Next line the Driving Rail up with the Drive Rail Assembly and the Adjuster Block with the Adjuster Rail on the Stitcher Machine. At this point, the top of the Head should slip over the Bonnet Clamp Block in the Upper Bonnet Rail. Start to tighten the Eccentric or Handle at the top of the Head then completely tighten the Eccentric or Handle at the bottom. Completely tighten the Eccentric or Handle at the Bottom of the Head and verify that the Head is mounted securely to the M27. The Clincher Plate Assemblies can now be aligned with the Stitcher Head, see page 13 for more details.

To remove a Stitcher Head from the M27: While completely supporting the Stitcher Head, turn the Bonnet Clamp Eccentrics or raise the Bonnet Clamp Handles until the Stitcher Head is released from the M27. Lift the Head off the Bonnet Clamp Blocks then remove the Blocks from the Bonnet Rails.

Clutch-Brake Maintenance

Always disconnect the power supply before making any adjustments or servicing the stitcher

! WARNING

This stitcher is equipped with a solenoid actuated, continuous trip, wrap spring clutch-brake unit. It is a dependable device and seldom needs service. But should a malfunction occur, the following information is a service and troubleshooting guide for the maintenance of this unit.

Actuator

The actuator is a simple, straight-forward mechanical linkage. When the actuator does not trip, the following checks should be made. Refer to **Figure 10** for more details.

Problem	Cause and Remedy
No power to the Coil	Check all wiring and switching in the Clutch actuating system.
Lack of continuity in the Coil Windings	Replace the Coil (850998 - 230 VAC or 850999 - 115 VAC)
Mechanical binding of the Plunger	The Coil may have shifted or the Plunger end may have mushroomed due to striking the Backstop. In the latter the Plunger may be filed to its true diameter.
Insufficient clearance for the Actuator over the Stop Collar	Adjust the Linkage as needed
Actuator loaded by the Stop Collar so hard that the Actuator cannot be pulled by the Coil.	Braking force is exceeding the limits of the Brake or the Differential setting of the unit is too close (see Figure 12 for instructions)

Figure 10 - Actuator Checklist

Clutch and Brake Springs

With the brake engaged (full limit of output), the input hub should be free to rotate by hand. With the clutch engaged, the input and output hubs should rotate together. If the unit does not rotate in either of these modes, the clearance between the hubs of the unit on the shaft may have been disturbed or damaged. See Assembly/Disassembly instructions for re-adjusting.

Listed below are additional checks to be made if the clutch does not function correctly. Refer to **Figure 11** for details.

Problem	Cause and Remedy
Clutch Brake does not drive but Input Motor turns	<ol style="list-style-type: none"> 1. Drive Spring (850889) may be broken at the crossover point from an overload caused by a jam. Replace the Spring and check the Hubs (851321 or 850892) for damage. 2. The Control Collar (850888) may not snap forward because of foreign matter restricting movement. Clean unit. 3. Actuator Assembly does not pull in. (Figure 28)
Clutch Brake jams and stalls Input Motor	<ol style="list-style-type: none"> 1. Spring tang broken off Drive Spring not allowing e Clutch to disengage while the Brake is engaged. Replace the Drive Spring. 2. Clutch output is bound up. Check the clearance between the Output Hub and the Brake Hub. 3. Completely out of adjustment caused by losing an internal Spring tang. Replace Spring.
Output does not repeat stopping point	<ol style="list-style-type: none"> 1. Not enough inertia to actuate Brake. 2. Tang broken off the Brake Spring. Replace the Spring. 3. Adjustable Collar Locking Screw may be loose allowing Adjusting Screw to rotate.

Figure 11 - Clutch and Brake Spring Checklist

Disassembly (Figure 12)

To disassemble the Clutch-Brake unit (850677 or 850678) it will be necessary to remove the Drive Pulley (7678) from the stitcher by removing the V-Belt (850730C), Retaining Ring (P7863), and Clutch Anchor Screw (7681). Disconnect the Ground and Solenoid wires, and swing the anchor strap (FC9656) clear of the Drive Pulley Assembly and slide it off of the Drive Shaft. Remove the three (3) Screws (UA4812.7) connecting the Drive Pulley to the Clutch-Brake unit.

When disassembling the Clutch-Brake unit, always mark the Spring Tang locations with reference to which slots they go in if the same Springs are to be used for reassembly. To disassemble the Clutch-Brake unit, proceed as follows:

Release the Actuator Lever so that the Clutch is engaged and the Brake is released. Remove the Retaining Ring and the Shim Washer, if any, from the Input Hub (851321) end. Remove the Input Hub by rotating opposite to the drive direction. Remove the Retaining Ring and the Shim Washer, if any, from the Mounting Plate end.

Remove the Output Shaft Springs and the Control Collar (850888) Assembly by rotating the Output Shaft (850891) in the drive direction. **(Do not disassemble the brake Hub (850892) from the Mounting Plate. (850890))** Remove the Control Collar from the Output Shaft and the Spring Assembly by extracting toward the Brake Spring end.

Assembly (Figure 12)

Replace the Clutch (850888), Brake (850889) and Anti-Back (850962) Springs as required. Assemble the Springs concentric and square to the Output Shaft.(850891) Assemble the Control Collar over the Output Shaft and Spring Assembly by inserting it from the Brake Spring End (it will be necessary to extend the Brake Springs using long nose pliers.) Place the Brake Spring Tang in any one (1) of the nine (9) Control Collar slots at random.

Assemble the Output Shaft, Springs and Control Collar assembly to the Mounting Plate Assembly by rotating the Output Shaft in the drive direction. Assemble the Retaining Ring (850886) to the Output Shaft at the Mounting Plate end (the smooth surface facing the Brake Hub.) Check the end play between the Hub and the Retaining Ring with a feeler gauge. There should be 0.004” to 0.010” end play. Use a Shim Washer to adjust if necessary.

Rotate the Output Shaft in the drive direction until it reaches a full brake position. With the Clutch Spring Tang **NOT** in slot, insert the Input Hub (851321) by rotating opposite to the drive direction. Select one (1) of ten (10) Control Collar slots for the Clutch Spring Tang that will provide a 0.38” to 0.50” circumferential overtravel of the Control Collar when released.

Note: At this point it may be necessary to reselect one (1) of the nine (9) Control Collar slots for the Brake Spring Tang (release Actuator Lever, remove the Clutch Spring tang from the slot, then move Control Collar axially toward the Input Hub end and rotate it opposite to the drive direction to pick up the next slot). Continue to select Control Collar slots until the 0.38" to 0.50" specification is achieved.

Assemble the Retaining Ring to the Output Shaft at the Input Hub end (the smooth surface facing the Input Hub). Check the end play between the Input Hub and the Retaining Ring with feeler gauge. There should be 0.002" to 0.003" end play on the Input Hub.

Reassemble the unit to the machine.

Note: After the Clutch is assembled to the machine, the Clutch Plate should be free to float on bearing - the Anchor Strap is only there to prevent rotation of the plate.

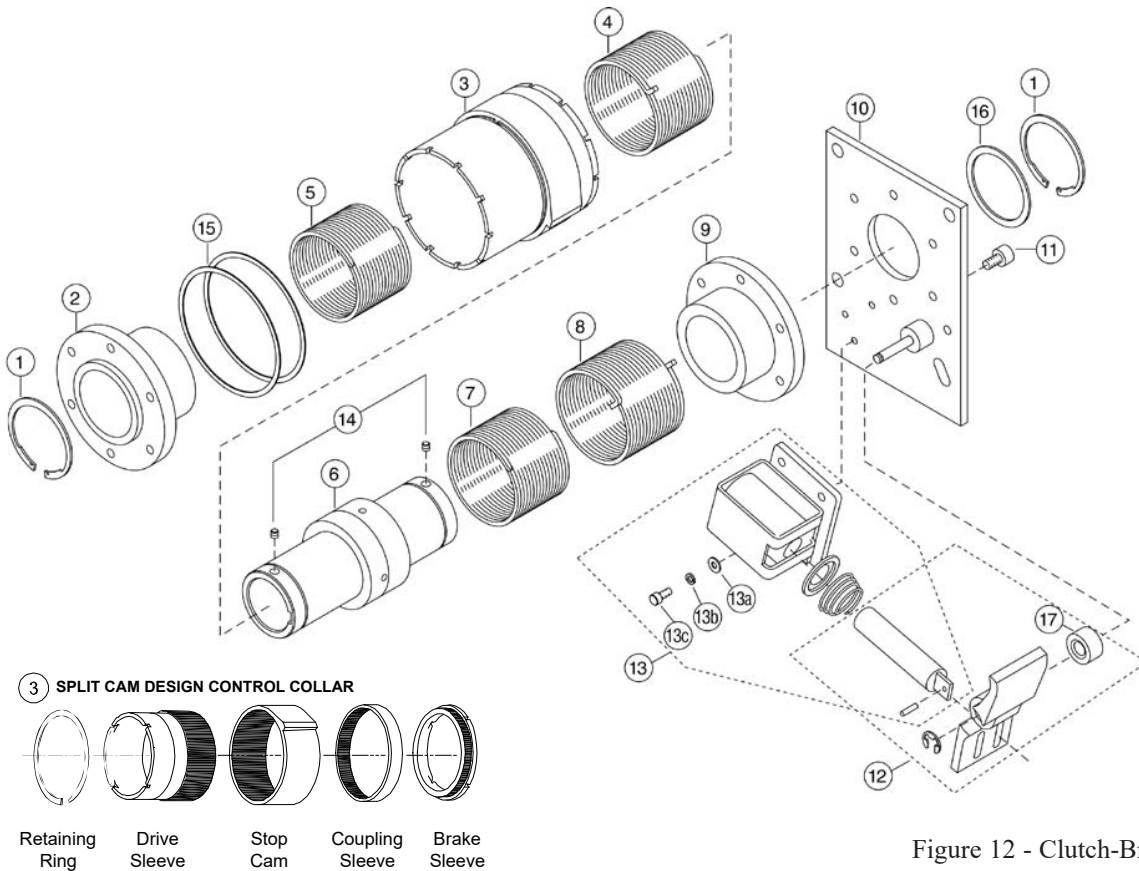

Figure 12 - Clutch-Brake

Item	Description	Part No.
1	Thrust Washer (Input)	N/A
2	Input Hub Assembly w/Roller Bearing	850884
3	Control Collar Assembly	851767
4	Drive Spring	850804
5	Anti-Overrun Spring	***NOT USED***
6	Output Assembly SPCL	850965
7	Anti-Back Spring	850964
8	Brake Spring	850805
9	Brake Hub w/Roller Bearing	850961
10	Plate Assembly	850960
11	Thrust Washer (Plate Hub)	N/A

Item	Description	Part No.
12	Actuator Assembly w/Plunger	850974
13	Button Head Cap Screw	850959
14	Coil Assembly - 230V-50Hz	850998
	Coil Assembly - 115V-60Hz	850999
15	Headless Socket Set Screw	850873
16	Retaining Ring	850801
17	Shims	850872
18	Shims (Clutch Shim .005")	850871
	Shims (Clutch Shim .010")	850870
19	Spacer	850869

Lubrication

The clutch-brake unit is designed with the bearing parts made from sintered metal that has been impregnated with oil and normally do not need to be re-lubricated. In cases where there is severe duty, the unit may be re-oiled or flushed out with minimal or no disassembly by using a light bearing oil as used in manufacture (Shell Bearing Infusion Oil #33). If disassembly of the unit for cleaning and oiling is necessary, follow the detailed disassembly instructions to the point needed, flush and wipe parts in the oil to be used for re-lubrication. **Do not use solvents** to clean the parts. To get more cleaning action for the oil, it may be heated while cleaning the components, but bring the parts back to ambient temperature submerged in cool oil.

Coil Replacement

Place the spring onto the plunger with the narrow end towards the actuator. Slide the solenoid onto the actuator and plate assembly. Assemble the solenoid to the plate assembly with the cap screws and washers. **Do not tighten** more than finger tight.

Energize the coil and adjust the gap between the actuator and the top of the collar stop to 0.015" to 0.030" by sliding the solenoid assembly. Note: push the collar toward the actuator to allow for collar movement. Tighten the cap screws.

Control Collar Adjustment (Figure 13)

The stopping position of the head can be changed if necessary by adjusting the position of the stop cam on the control collar sleeve. Turn the machine manually until the driver is in the desired stopping position, the proceed as follows:

Work the Retaining Ring out of its groove and slide it forward on the Drive Sleeve. Slide the cam of the Control Collar Assembly (850888) off of the splines, rotate to align the collar stop with the actuator and slide the cam back on the splines. The actuator pawl will have to be held clear during this operation. Slide the retaining ring back into its groove.

Make sure brake is locked up before proceeding, to insure the proper stop point.

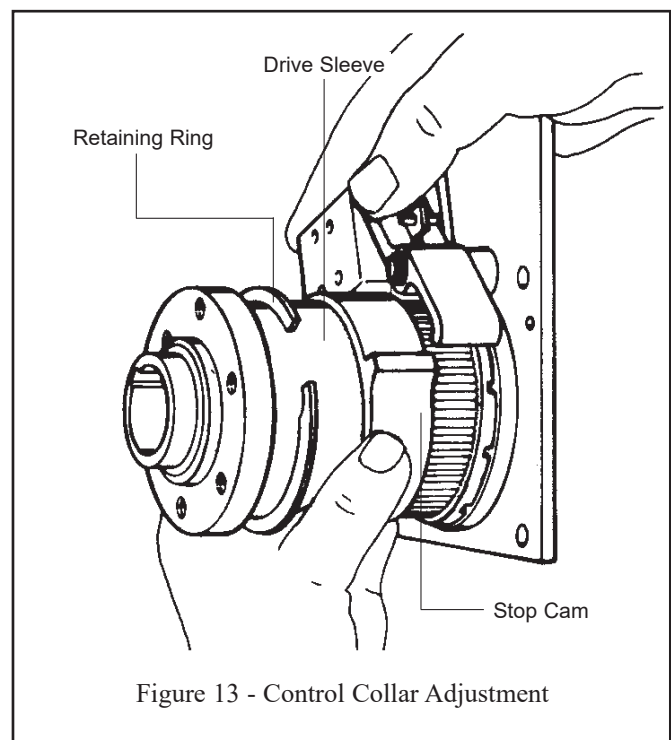
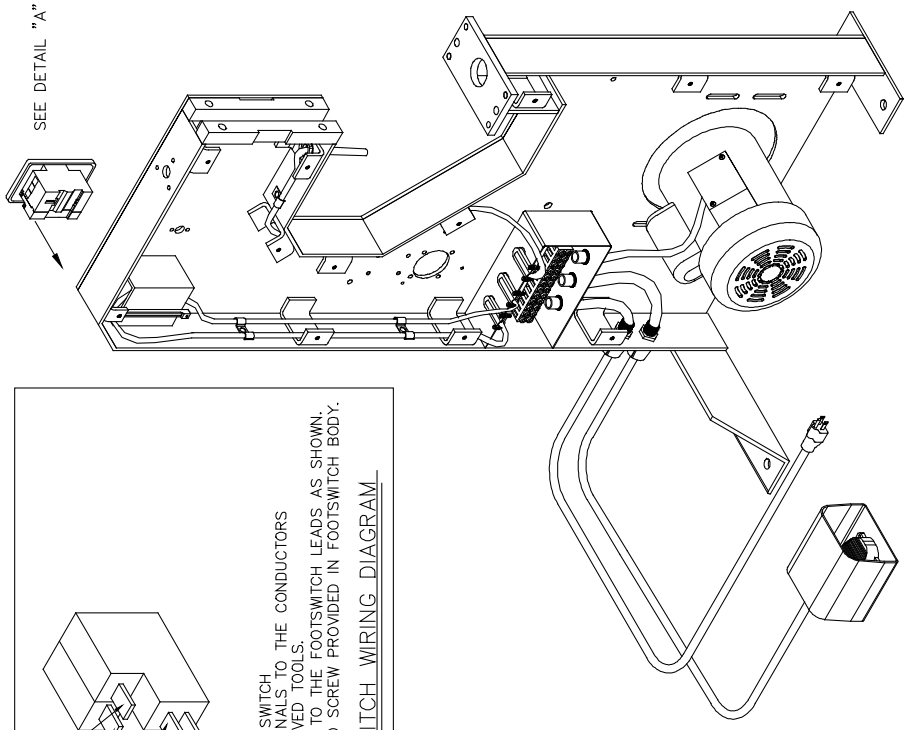
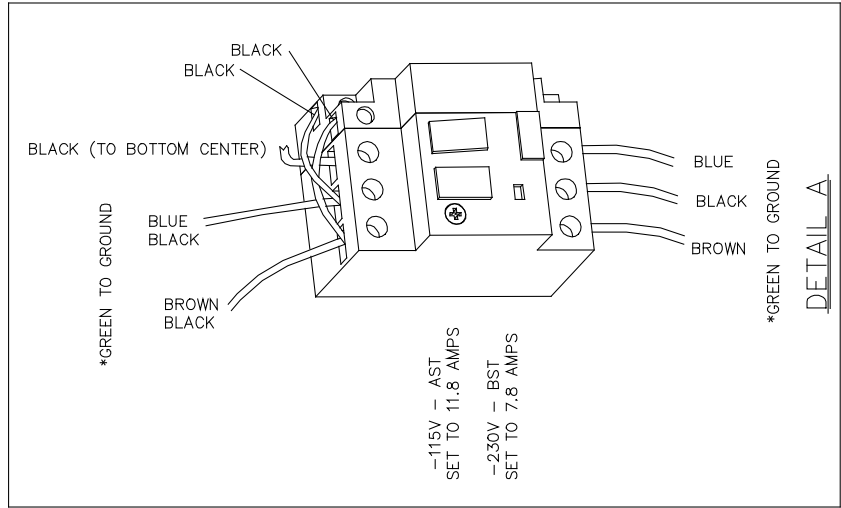

Figure 13 - Control Collar Adjustment

Wiring Diagram



NOTE:
 1. STANDARD D.P.D.T. SWITCH
 2. ATTACH WIRE TERMINALS TO THE CONDUCTORS USING ONLY APPROVED TOOLS.
 3. FASTEN TERMINALS TO THE FOOTSWITCH LEADS AS SHOWN.
 4. FASTEN GROUND TO SCREW PROVIDED IN FOOTSWITCH BODY.

FOOT SWITCH WIRING DIAGRAM

Complete Wiring with Detail

Wiring Diagram

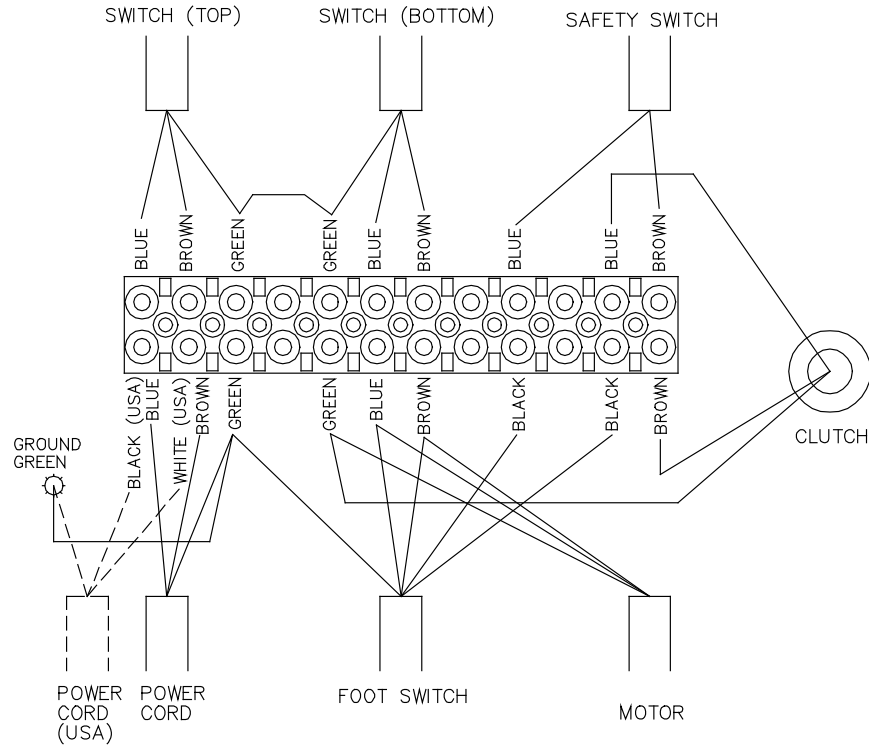

AST - 115V Models

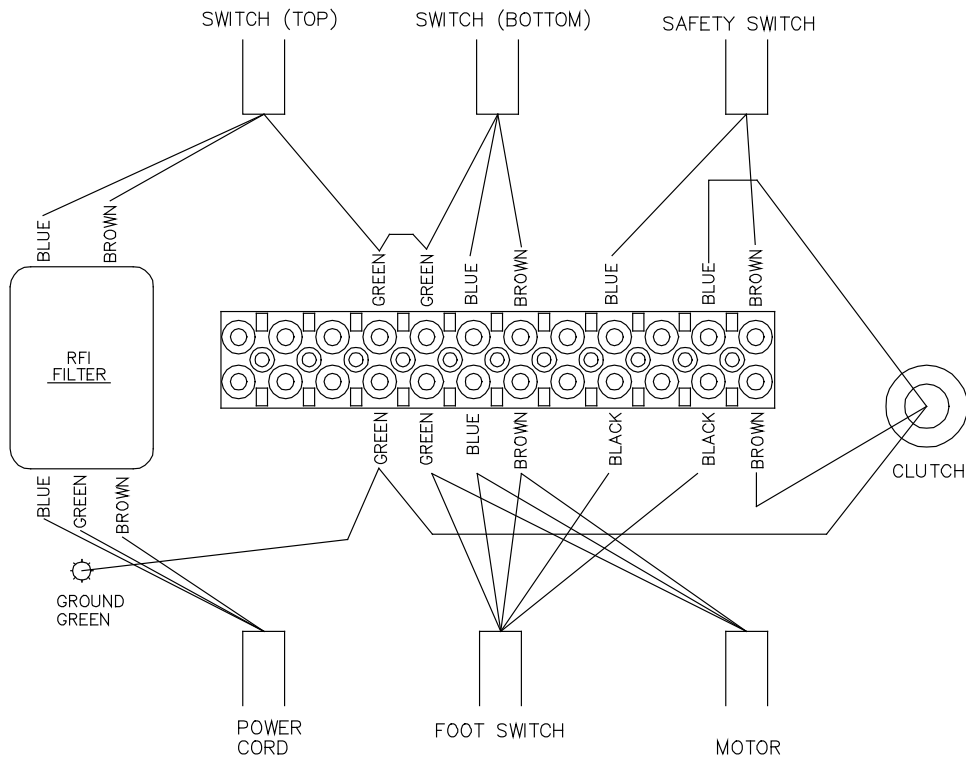

BST - 230V Models

Motor Assemblies

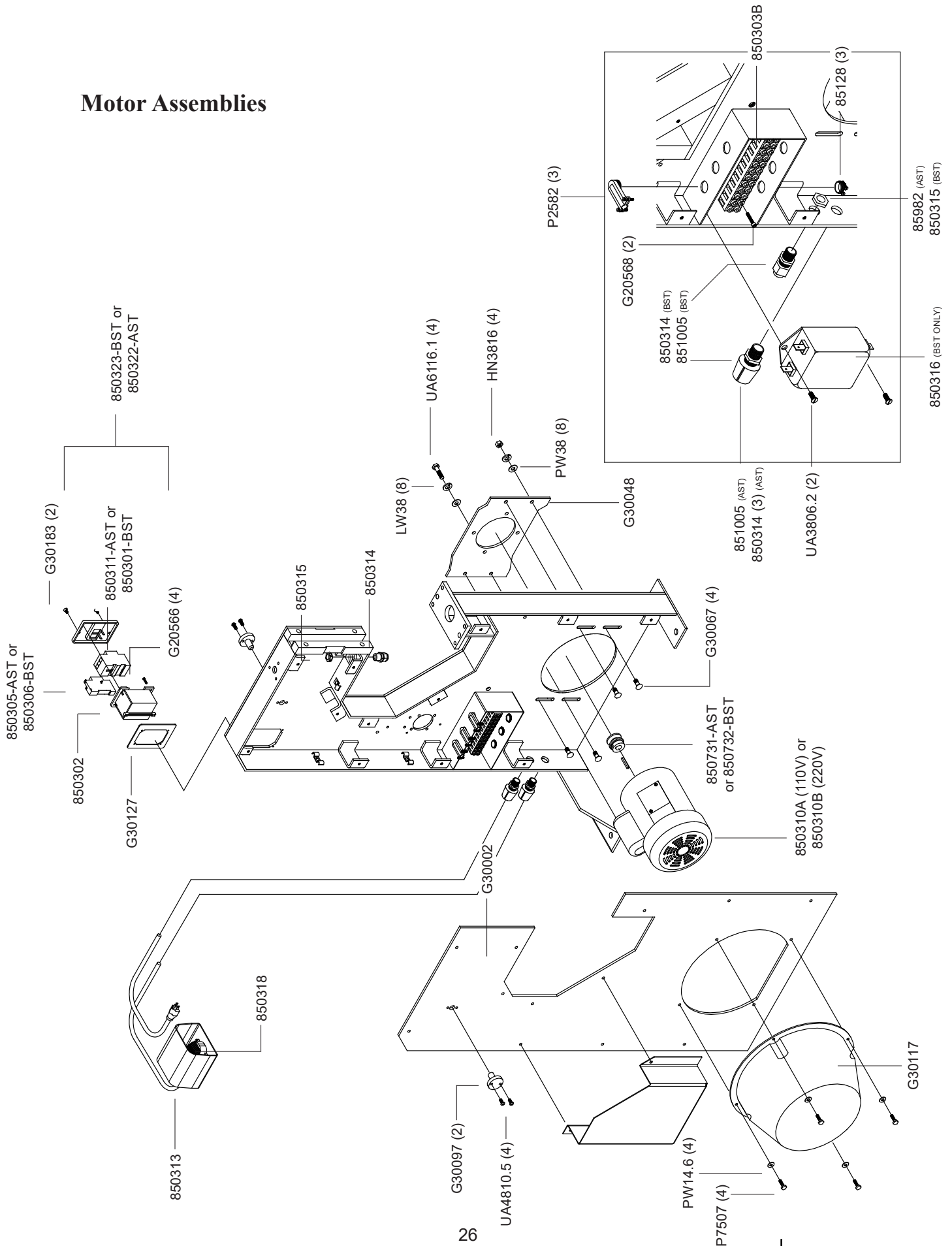

Internal Assemblies

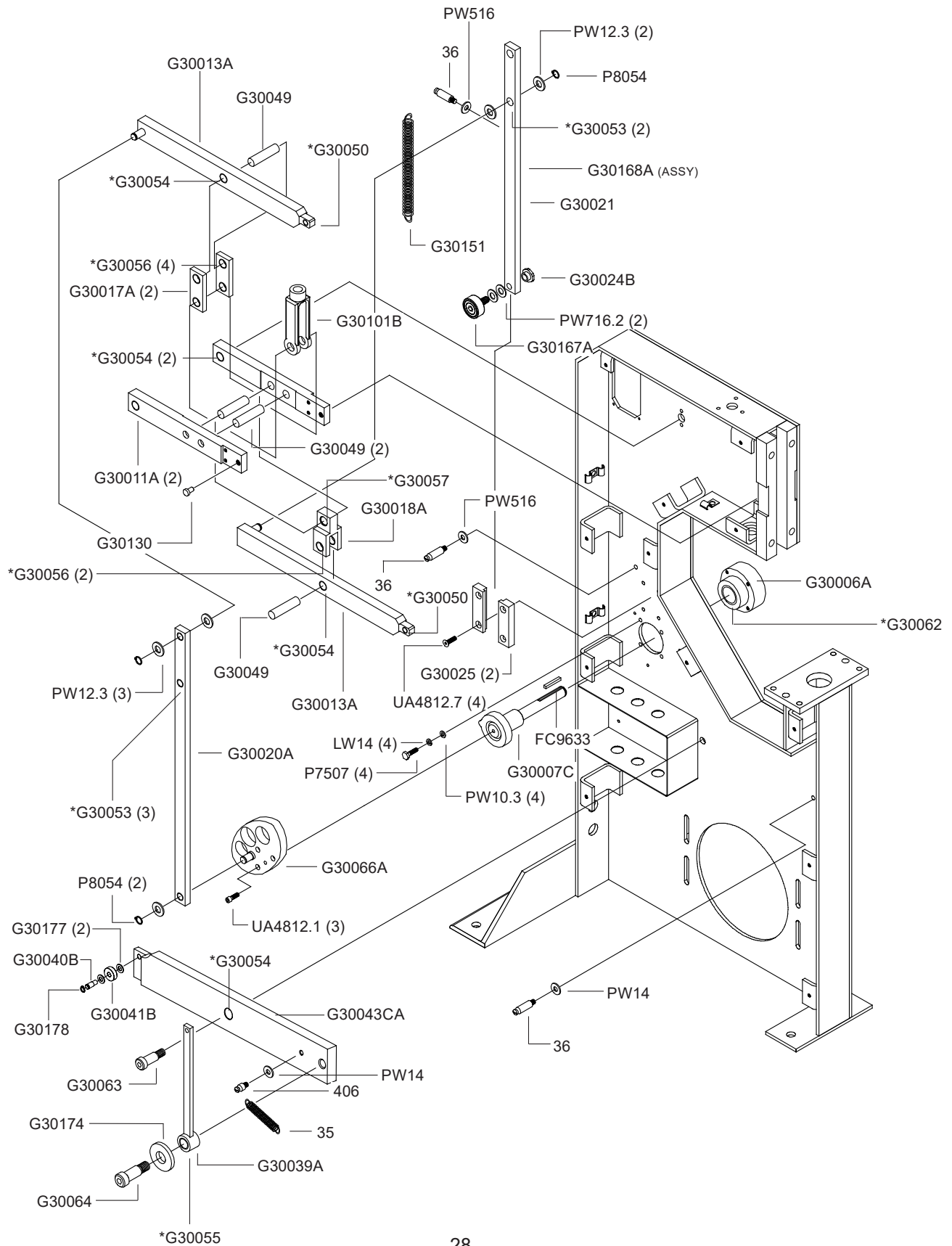

External Assemblies

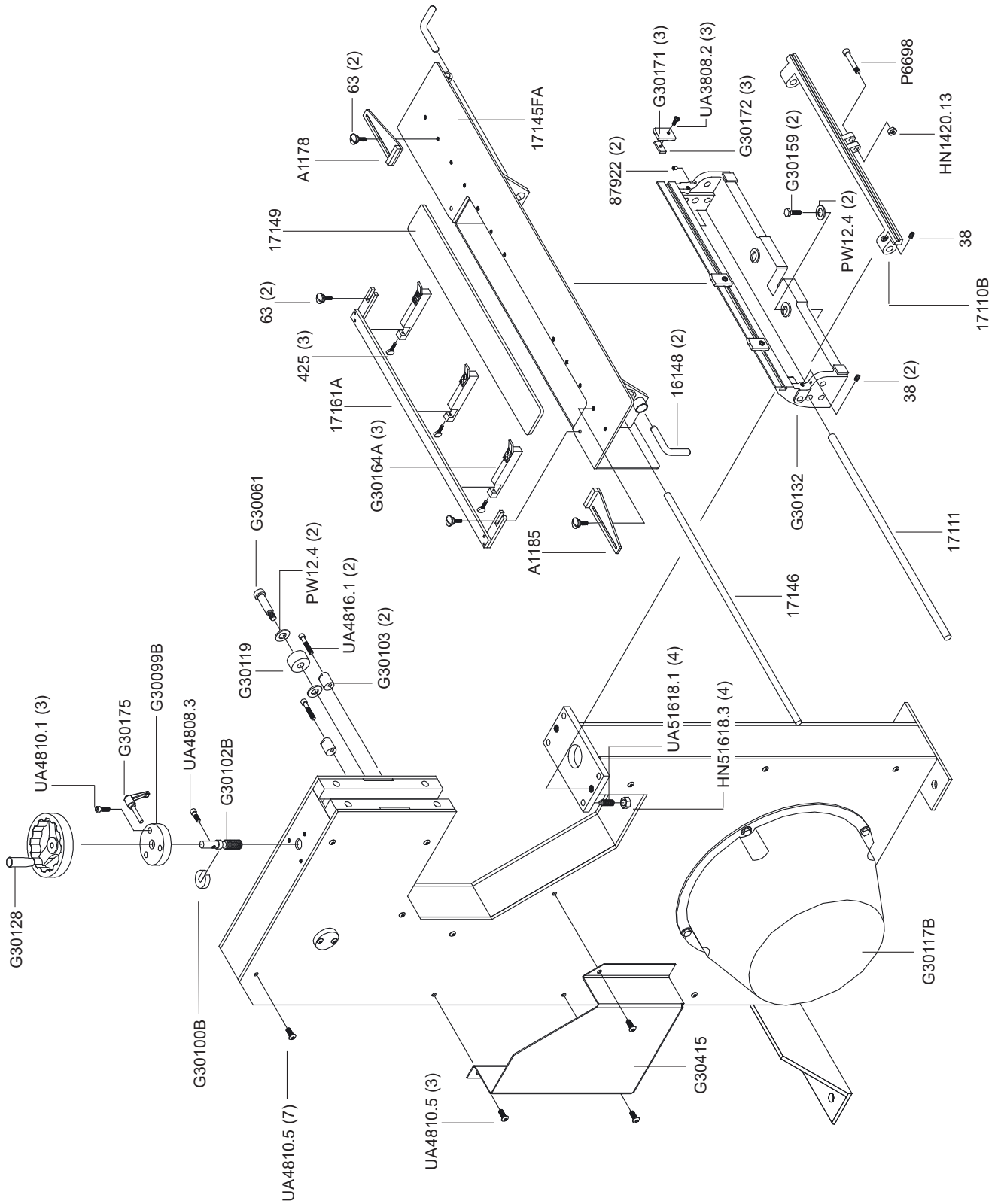

Driver and Bender Rail Assemblies

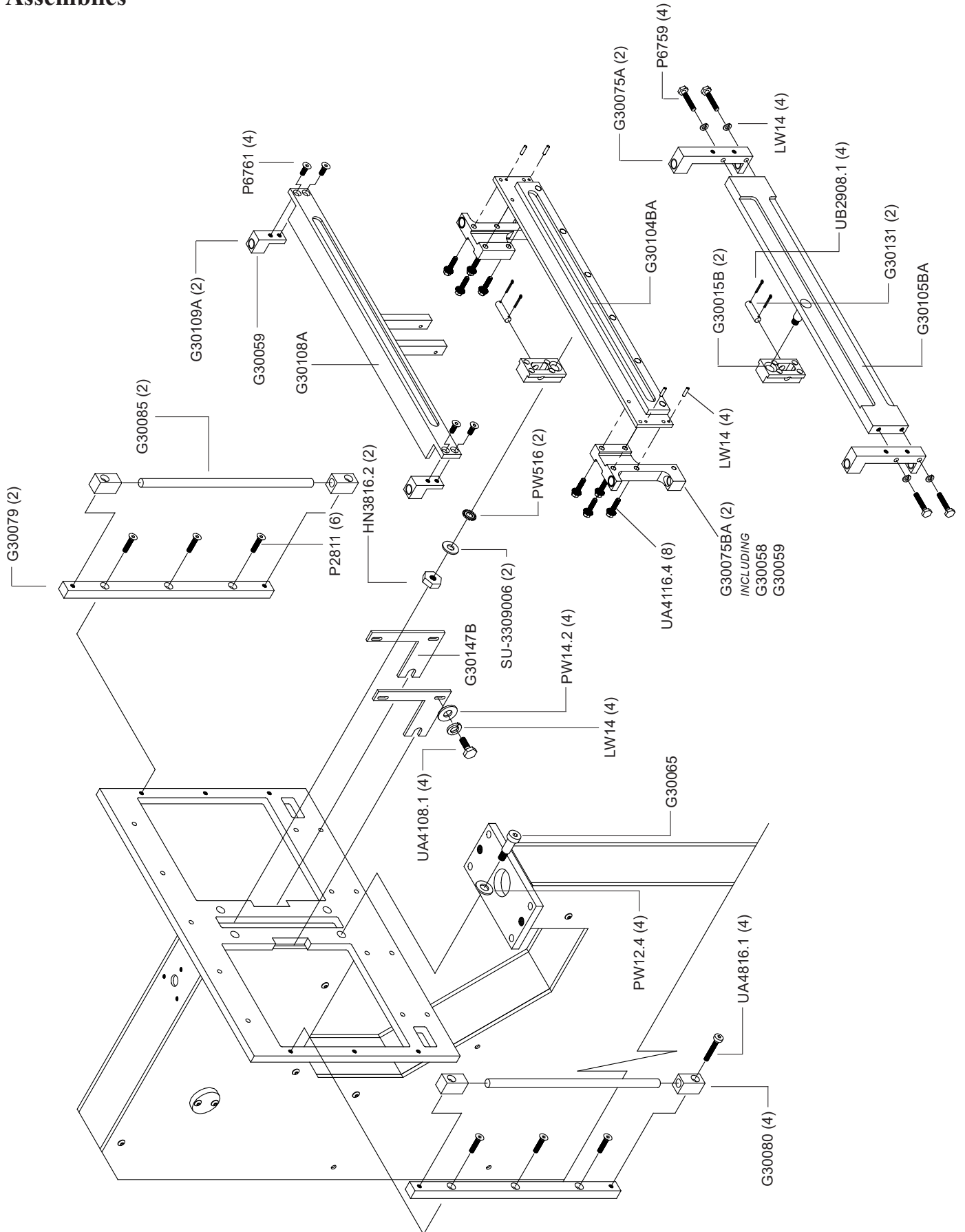

The M27 Stitcher Machine

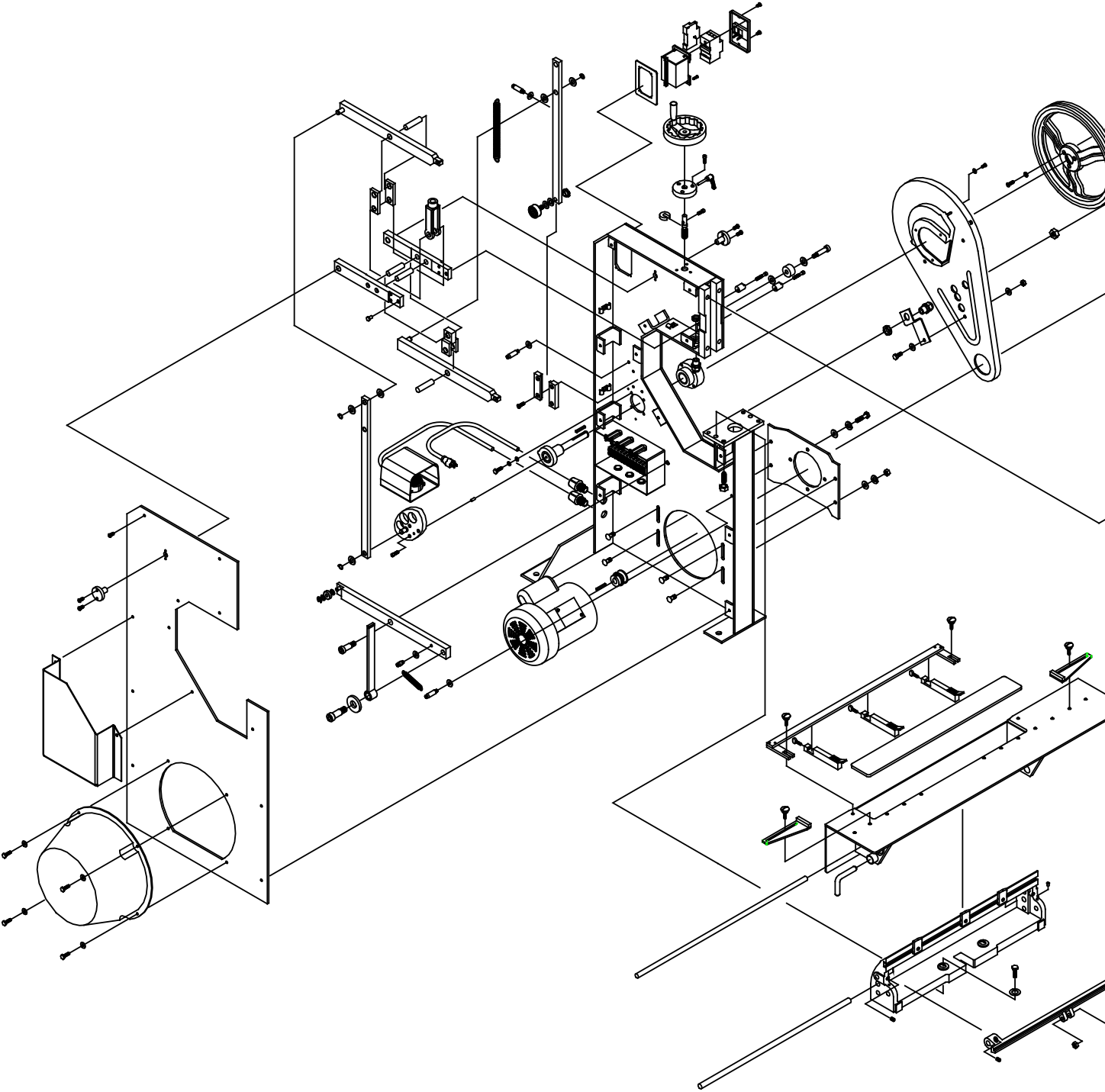

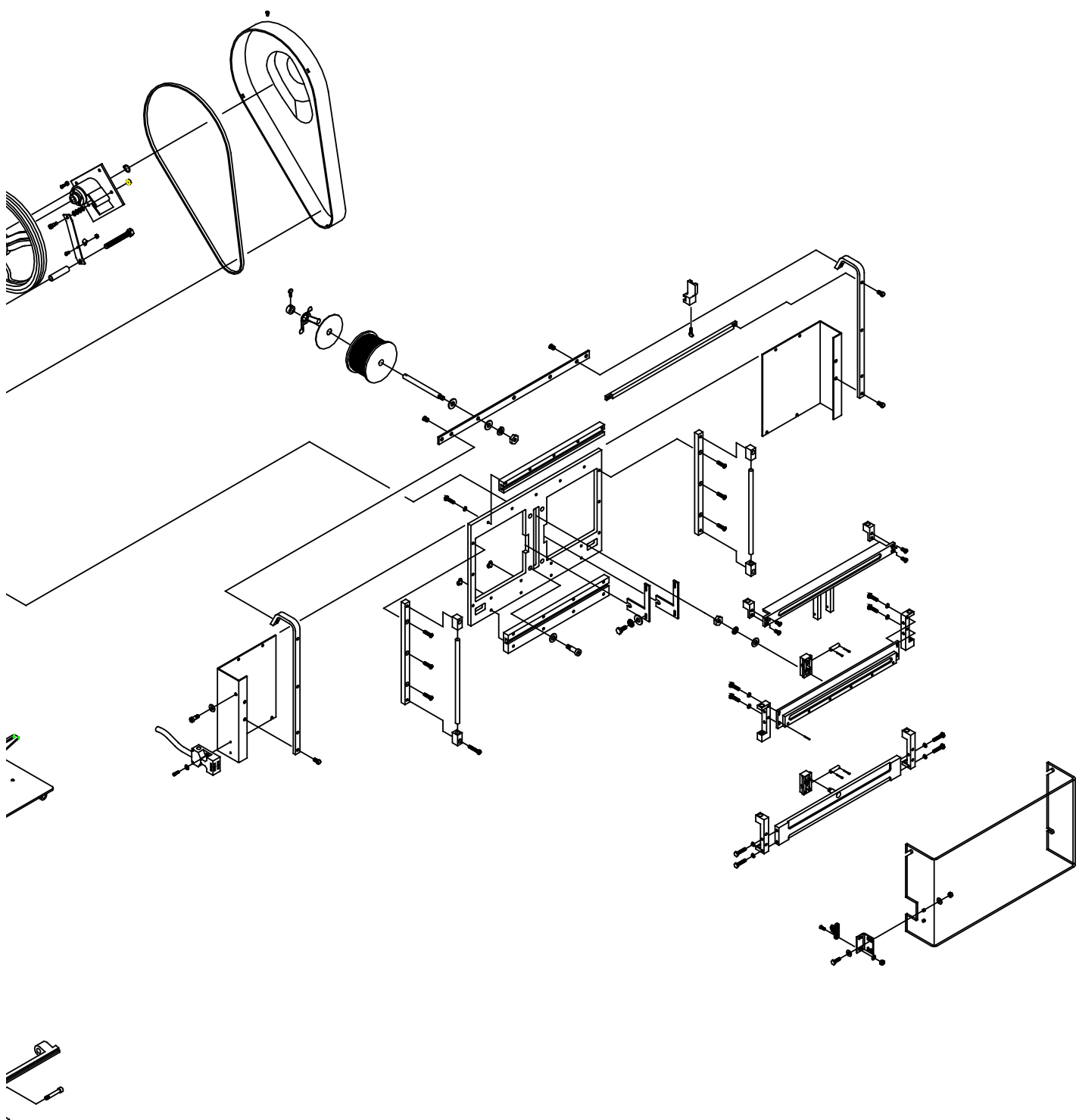

Part Number / Description Cross-Reference

PART NO.	DESCRIPTION	QUANTITY	PART NO.	DESCRIPTION	QUANTITY
072005	Screw, M6X1.0X25	1	850677	Electric Clutch 115V	1
16148	Table Lock Pin	2	850678	Electric Clutch 230V	1
17110B	Lever	1	850730C	V-Belt 1/2x60	1
17111	Pivot	1	850731	Pulley - AK15-5/8	1
17145FA	Work Table Assembly	1	850732	Pulley - AK17-5/8	1
17146	Pivot	1	851005	Strain Relief	2
17149	Plate	1	85128	Connector 3/8	3
17161A	Back Gauge Bar Assembly	1	851742	Wire 90 Degree Disconnect	5
17280	Spool Bar	1	85982	Lock Nut 1/2	1
17281	Screw 3/8-16X5/8	2	86243	Power Cord - 115V	1
17282	Spool Bar Bracket	2	87922	Oil Hole Cover	2
17288	Wire Guide Spring Holder	1	88038	Nylon Cable Clamp	2
17289	Wire Guide Spring Bracket Bar	1	9079	Supporter Guide Plate Dowel	4
18502	Drive Pulley, CB-7 Clutch	1	A1178	Side Paper Guide - RH	1
18001MHD20241/2	Stitcher Head Assembly - M27	2	A1185	Side Paper Guide - LH	1
35	Clincher Slide Link Spring	1	AF250	Dowel Pin 1/8x1	4
36	Pin	3	FC9633	Key	1
38	Clincher Slide Adjustment Screw	3	FC9656A	Clutch Anchor Assembly	1
406	Clincher Oper. Lever Spring Screw	1	G20566	Screw M4x0.7x20	4
425	Wire Guide Spring Holder Screw	4	G20MHD19211/2	G20 Stitcher Head - M27	2
63	Work Guide Screw	4	G30001A	Frame Weldment	1
7675	Belt Guard	1	G30002	Side Cover Plate - Left	1
7676	Belt Guard	1	G30006A	Bearing Housing Assembly	1
7678B	Drive Pulley - 4L	1	G30007C	Crank Shaft Assembly	1
7681	Screw Clutch Anchor	1	G30011A	Adjuster Lever Assembly	2
7690	Tension Spring	2	G30013A	Drive Lever Assembly	2
7691	Set Collar - Reamed	2	G30015B	Slider	2
7693	Spool Stud	2	G30017A	Pivot Link Assembly	2
850301	Motor Starter GV2M14	1	G30018A	Pivot Fork Assembly	1
850302	Starter Enclosure	1	G30020A	Upright Link Assembly	1
850303B	Terminal Strip - Holes	1	G30021	Cam Upright Link	1
850305	UV Trip - 115V	1	G30024B	Hex Nut Guide Stud	1
850306	UV Trip - 230V	1	G30025	Cam Guide	2
850307	Power Cord - 230V	1	G30039A	Clincher Upright Link Assembly	1
850308	Safety Interlock Switch	1	G30040B	Cam Follower Stud	1
850310A	Motor 3/4 HP - 115V	1	G30041B	Clincher Cam Follower	1
850310B	Motor 3/4 HP - 230V	1	G30043BA	Clincher Lever Assembly	1
850311	Motor Starter GV2M16	1	G30048	Motor Mounting Plate	1
850313	Footswitch Guard	1	G30049	Dowel Pin 5/8x2-1/2	4
850314	Strain Relief	2	G30061	Screw 1/2x1-1/2	1
850315	Strain Relief Nut	2	G30063	Screw 5/8x1	1
850316	RFI Filter, AC Noise	1	G30064	Screw 3/4x1-1/4	1
850317	Clutch, Wire Harness	1	G30065	Screw 1/2x1	1
850318	Footswitch, Wired	1	G30066A	Bender Cam Assembly	1
850319	Safety Switch, Wired	1	G30067	Bolt 3/8-16x1	4
850322	Starter Assembly - 3/4,115V	1	G30075A	Guide Rod Slider Assembly	4
850323	Starter Assembly - 3/4, 230V	1	G30078	Multi Head Face Plate Adapter	1
850332	Motor Harness Wire, Short	1	G30079	Face Plate Side Rail	2
850337	Wire Terminal Ring	1	G30080	Guide Rod End Cap	4
850343	Interlock Switch Key	1	G30085	Slider Guide Rods	2
850660	CB-7 Clutch - 115V	1	G30097	Adjuster Pivot Pin	2
850661	CB-7 Clutch - 230V	1	G30099B	Adjustment Crank Housing	1

Part Number / Description Cross-Reference

PART NO.	DESCRIPTION	QUANTITY	PART NO.	DESCRIPTION	QUANTITY
G30100B	Adjuster Crank Shaft Insert	1	LW14	Lock Washer 1/4	16
G30101B	Adjuster Yoke	1	LW38	Lock Washer 3/8	9
G30102B	Adjuster Shaft	1	M11009	Plastic Washer	1
G30103	Adjuster Stop	2	P2582	Connector 3/8x90 Degrees	3
G30104BA	Driving Rail Assembly	1	P2731	Thumb Screw 1/4-20x3/4	1
G30105BA	Bender Rail Assembly	1	P2811	Screw 1/4-20x1	6
G30106	Bonnet Rail - Lower	1	P3318	Screw 5/16-18x3/4	4
G30107	Bonnet Rail - Upper	1	P6371	Retaining Ring	1
G30108A	Adjuster Rail Assembly	1	P6698	Shoulder Bolt 5/16x1	1
G30109A	Guide Rod Slider Assembly	2	P6759	Screw 1/4-20x1-1/4	4
G30117B	Motor Cover	1	P6761	Screw 1/4-20x1/2	4
G30118	Belt Guard Bracket	1	P7507	Screw 1/4-20x3/4	10
G30119	Adjuster Spool	1	P7863	Retaining Ring	1
G30124	Actuator Key Bracket	1	P8054	Retaining Ring	3
G30127	Starter Mounting Flange	1	PG10271	Washer 9/16	1
G30128	Hand Wheel	1	PW10.3	Washer 3/16	3
G30130	Adjuster Stud	1	PW10.6	Washer S.A.E. #10	2
G30131	Slider Pin	2	PW12.3	Washer Zinc 1/2	5
G30132	Clincher Rail	1	PW12.4	Washer Black 1/2	8
G30133	Guard Mount - Left	1	PW14	Washer 1/4	19-25
G30134	Guard Mount - Right	1	PW14.2	Washer Zinc 1/4	4
G30135	Head Guard	1	PW14.6	Washer	4
G30147B	Adjuster Fork	2	PW38	Washer 3/8	9
G30150	Extension Spring	1	PW516	Washer 5/16	4
G30151	Extension Spring	1	PW716.2	Washer 7/16 SAE	2
G30159	Screw 1/2-20x1-1/4	2	SU-0308853	Screw 3/8x3/8	3
G30163	Self Tap Screw 10x3/8	2	SU-3309006	Lock Washer 3/8	2
G30164A	Back Stop Gauge 3/4"	3	SW14.1	Lock Washer	3
G30167A	Cam Follower Assembly	1	SW516.2	Lock Washer	1
G30168A	Cam Upright Link Assembly	1	UA3806.2	Screw 10-32x3/8	2
G30171	Centering Guide M27	3	UA3806.9	Screw 10-32x3/8	3
G30172	Center Guide Plate - M27	3	UA3808.1	Screw 10-32x1/2	2
G30174	Spacer - M Series	1	UA3808.2	Screw 10-32x1/2	5
G30175	Adjuster Crank	1	UA4808.3	Screw 1/4-20x1/2	1
G30176	Screw M4x0.7x25	2	UA4108.1	Screw 1/4-20x1/2	4
G30177	Flat Washer	2	UA4116.4	Screw 1/4-20x1	17
G30178	Retaining Ring	1	UA4810.1	Screw 1/4-20x5/8	3
G30183	Screw, Tap 6x3/8	2	UA4810.5	Screw 1/4-20x5/8	12
G30200	Adapter, CB-7 Clutch	1	UA4812.1	Screw 1/4-20x3/4	3
G30201	End Cap, CB-7 Clutch	1	UA4812.7	Screw 1/4-20x3/4	7
G30202	Key-Rectangular, CB-7 Clutch	1	UA4816.1	Screw 1/4-20x1	6
G30203	Crank Shaft, CB-7 Clutch	1	UA5112.1	Screw 5/16-18x3/4	1
G30204	Clutch Anchor, CB-7 Clutch	1	UA5116.1	Screw 5/16-18x1	6
G30415	Tool Kit Hanger	1	UA51618.1	Screw 5/16-18x7/8	4
HN1213.2	Nut 1/2-13	1	UA5210.1	Screw 5/16-18x5/8	2
HN1420.13	Nut 1/4-20 Nylon	3	UA6111	Screw 3/8-16x5/8	2
HN3816	Hex Nut 3/8-16	5	UA6116.1	Screw 3/8-16x1	4
HN3816.2	Hex Jam Nut 3/8-16	2	UA8164	Screw 1/2-13x4	1
HN51618	Hex Nut	2	UB2908.1	Supporter Spring Cotter Pin	1
HN51618.3	Hex Jam Nut 5/16-18	4			
KN1032	Kep Nut 10-32	4			
KN1420	Kep Nut 1/4	1			



Declaration of Conformity

We, DeLuxe Stitcher Company, Inc.

3747 North Acorn Lane
Franklin Park, Illinois 60131, U.S.A
Telephone 847-455-4400
Fax 847-455-4900

hereby declare under our sole responsibility that the

M27-BST Stitching/Stapling Machines

to which this declaration relates is in conformity with the following European product safety directives:

Machinery Safety Directive

(89/392/EEC and amendments
91/368/EEC, 93/44/EEC, 93/68/EEC)

Electromagnetic Compatibility Directive

(89/336/EEC and amendments
91/C162/08, 92/31/EEC, 93/68/EEC)

as is verified by compliance with the following standards:

EN 60204-1:1992	prEN 894-1:1992	prEN 953:1992
EN 294:1992	prEN 894-3:1992	EN 55014:1193
prEN 614-1:1991	prEN 1050:1993	EN 55104:1995

Executed for DeLuxe Stitcher Company, Inc.

this first day of January in the year 2009

By Frank P. Cangelosi Signature *Frank P. Cangelosi*

Title President



mybinding.com
1-800-944-4573

PLACE
STAMP
HERE

DELUXE STITCHER
COMPANY, INC.
3747 North Acorn Lane
Franklin Park, Illinois 60131, U.S.A.
Attn: Customer Service

REGISTRATION

To better service your wire stitching needs, please take a moment to fill out and return this registration card.

Name : _____
(First) (Middle Initial) (Last)
Company : _____
Street Address : _____
City : _____ State/Province : _____ Zip : _____
Country : _____
Phone : _____ Fax : _____ E-mail : _____

CUSTOMER

Machine(s) Purchased : _____
Serial Number(s) : _____
With Head(s) : _____
(Type/Quantity Purchased)
Serial Number(s) : _____
Head(s) Purchased : _____
Serial Number(s) : _____

PRODUCT

Date Received : _____
Dealer Name : _____
Dealer Street Address : _____
City : _____ State/Province : _____ Zip : _____
Country : _____
Dealer Phone : _____

DEALER

Other Bindery Products Used : _____

Please take a moment to fill out the attached card and mail it to DeLuxe Stitcher Company, Incorporated. In addition, duplicate the information for your records to assist when making further inquiries.

PRODUCT

Machine(s) Purchased : _____
Serial Number(s) : _____
With Head(s) : _____
(Type/Quantity Purchased)
Serial Number(s) : _____
Head(s) Purchased : _____
Serial Number(s) : _____

DE LUXE STITCHER GRAPHIC ARTS REPRESENTATIVE

Date Received : _____
Dealer Name : _____
Dealer Street Address : _____
City : _____ State/Province : _____ Zip : _____
Country : _____

Dealer Phone : _____

mybinding.com
1-800-944-4573

Would you like information sent to you about new products that would benefit your company? Yes No

LIMITED WARRANTY

DeLuxe Stitcher Company, Inc. warrants to the original retail purchaser that this product is free from defects in material and workmanship and agrees to repair or replace, at DeLuxe Stitcher's option, any defective product within 90 days from the date of purchase. This warranty is not transferable. It covers damage resulting only from defects in material or workmanship and does not cover conditions or malfunctions resulting from normal wear, neglect, abuse or accident.

This warranty is in lieu of all other express warranties. Any warranty of merchantability or fitness for a particular purpose is limited to the duration of this warranty. DeLuxe Stitcher shall not be liable for any incidental or consequential damages.

Some states do not allow limitations on how long an implied warranty lasts, or the exclusion or limitation of incidental or consequential damages, so the above limitations or exclusions may not apply to you. This warranty gives you specific legal rights and you may also have other rights which vary from state to state.

To obtain warranty service you must return the product, at your expense, together with proof of purchase to an authorized DeLuxe Stitcher Company, Inc. Graphic Arts Dealer.

Always use genuine DeLuxe Stitcher parts. When ordering parts, please identify the part number, the part name, the wire size and crown size of your Stitcher.

NOTES

WHEN ORDERING PARTS, PLEASE STATE: QUANTITY REQUIRED, PART NUMBER, PART NAME, WIRE SIZE AND CROWN WIDTH OF YOUR STITCHER.



COMPANY INC.

solving your wire stitching needs for 125 years...

ISP **Stitching & Bindery Products**

3747 Acorn Lane • Franklin Park • Illinois 60131

Phone: 847-455-4400 • 800-634-0810

Fax: 847-455-4900 • 800-417-9251

<http://www.deluxestitcher.com>

DBSM27 1122

MyBinding
When Image Matters.

mybinding.com
1-800-944-4573