

CUTWORX™

Complete Finishing Solutions

Powered by

CUTWORX™
Complete Finishing Solutions

Software Suite

eclipse
1523/2029

Installation Manual



mybinding.com
1-800-944-4573

- **Please read the manual carefully before using the product**
- **To ensure production safety, please read the "Safety Instructions"**

The design and use of this product comply with relevant specifications:

EN 60204-2018 Safety of machinery – Electrical equipment of machines

EN 61000-2011 Electromagnetic compatibility(EMC)



Safety Instructions



Note

All installation, operation and maintenance work should only be carried out by professionals.



Note

People and property maybe seriously injured in the following situations:

- ▲ Unauthorized removal of the cover
- ▲ Wrong installation and use



Note

Internal or external changes to the equipment can only be carried out after consultation with Eclipse or Eclipse dealer certified technician.



Note

The company is not responsible for safety injuries caused by the improper use of machine that is not authorized by Eclipse or Eclipse dealer certified technician.

Table of Contents

Safety Introductions

1.Machine Introduction	06
1.1 Eclipse 1523/2029 Digital Die Cutters Introduction.....	06
1.2 Eclipse 1523/2029 Technical Parameters.....	07
2.Machine Installation	08
2.1 Preparation Before Installation.....	08
2.1.1 Customer Installation Site Requirements.....	08
2.1.2 Other Preparations.....	08
2.1.3 Technician Requirements.....	08
2.2 List of Installation Tools.....	09
2.3 Unpacking Instructions.....	09
2.3.1 Unpacking Inspection and Notice.....	09
2.3.2 Check Before Unpacking.....	10
2.3.3 Installation of Equipment.....	11
2.3.4 Connection Between Machine and Computer.....	13
2.4 Computer Configuration.....	14
2.4.1 Windows Update.....	14
2.4.2 Driver Updates.....	15
2.4.3 Windows Boot Configuration.....	15
2.5 Eclipse Software Suite Installation.....	17
2.5.1 Folder Directory Setup.....	17
2.5.2 Cut Control Software Installation.....	17
2.5.3 Design Manager Installation.....	18
2.5.4 Configuring Admin & Security Privileges.....	19
2.6 License Key Software Installation.....	20
2.6.1 CodeMeterRuntime Installation.....	20

Table of Contents

2.6.2 iEcho Sentinel Software Installation.....	20
2.7 Pre-Boot Configuration.....	21
2.7.1 Power Supply Voltage Confirmation	21
2.7.2 Hardware Check.....	21
2.7.3 Air Pressure Confirmation	21
2.8 Booting the Eclipse.....	21
2.8.1 Booting Sequence.....	21
2.9 Hardware	22
2.9.1 DK 1.5mm/0.9mm Cut Tool	22
2.10 Feeding Device	24
2.10.1 Feeding Device Operation	24
2.10.2 Usage of Feeding Device	24
2.11 Suction Device	25
2.11.1 Working Principle of Suction Device	25
2.11.2 Positioning of Suction Cups and Materials.....	25
3.Eclipse Software Configuration	26
3.1 Design Manager Configuration	26
3.1.1 Cut Control Software Link.....	26
3.1.2 Camera Hardware Configuration.....	27
3.2 Cut Control Software Configuration	28
3.2.1 Serial Port Configuration.....	28
3.2.2 Cut Control Tool Bar Configuration	29
3.3 CCD Camera Calibration	32
3.3.1 CCD Camera Calibration Configuration	32
3.3.2 Registration Mark Calibration	35
3.3.3 Collecting Device Configuration.....	35

Table of Contents

4. Offset Cutting Test	37
4.1 EOT Tool Configuration	37
4.1.1 EOT Blade Introduction	37
4.1.2 Installation of EOT Blade	37
4.1.3 Material Press Plate Installation	38
4.1.4 Debugging of EOT Tool	38
4.1.5 EOT Tool Configuration	39
4.2 Calibration Test Cut File	43
4.2.1 Calibration Test Cut File Configuration	43
4.2.2 Start Calibration Sheet Cut	45
4.2.3 Tool Offset Adjustments	46
5. Support	48
5.1 TeamViewer Remote Support	48
5.1.1 Downloading TeamViewer.....	48
5.1.2 Remote Support Request.....	48
5.2 Troubleshooting	49
5.2.1 Communication Errors.....	49
5.2.2 Loading Device Troubleshooting.....	53
5.2.3 Cutting Issues.....	56
5.2.4 Conveyor Not Advancing After Cutting	57
6. Maintenance	58
6.1 Maintenance Schedule	58
6.2 Warranty	59

1. Machine Introduction

1.1 Eclipse 1523/2029 Digital Die Cutters Introduction

Eclipse Series Digital Die Cutters are efficient automatic sheet-fed digital cutting systems. The system can process vector graphics and convert them into cutting lines, then the motion control system drives the cutter module to complete cutting requirements. The equipment is equipped with a variety of cutting tools, so that creasing and cutting on different materials can be completed. With an integrated CCD Camera, continuous automatic sheet-fed production can be achieved on printed and non-printed materials.

Eclipse Digital Die Cutters are suitable for cutting the following materials:

Cardstock, self-adhesive materials, cardboard, KT board, PP plastic, corrugated board etc.

*** For more material choices, please contact CUTWORX USA support team.**

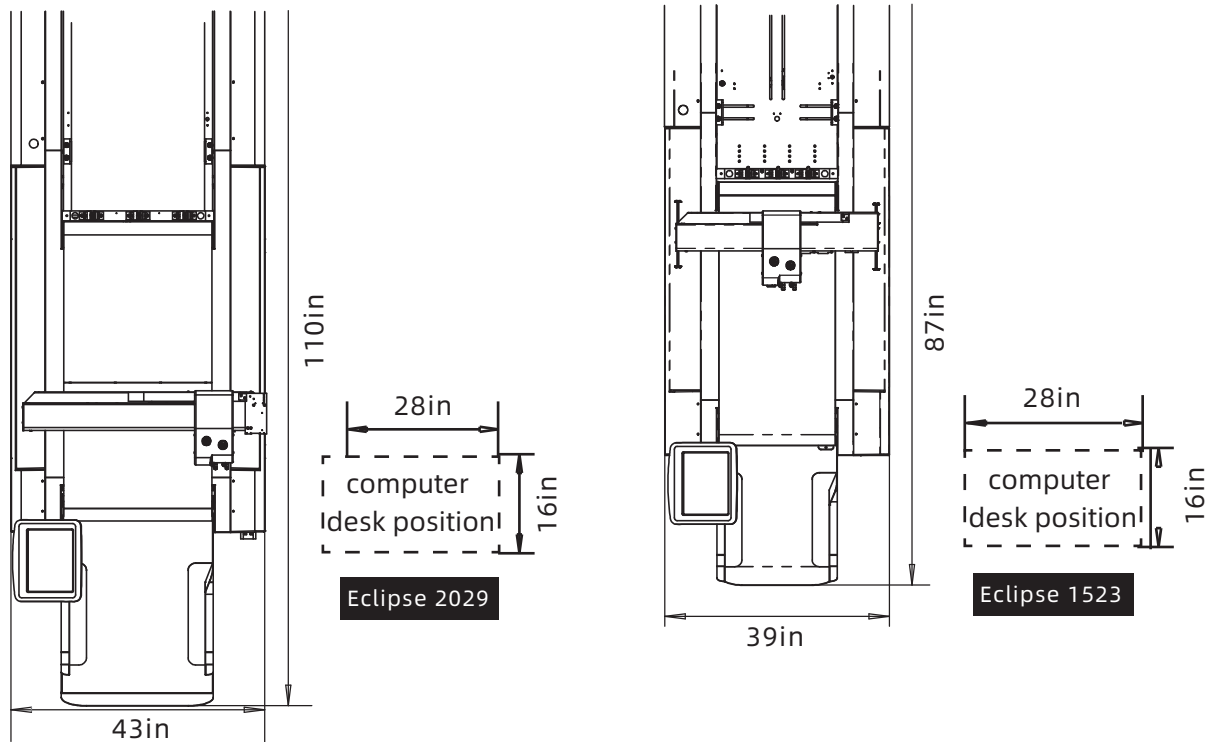

Note: The computer desk should be on the left or right side of the machine (about 16inx28in)

1.2 Eclipse 1523/2029 Technical Parameters

Model	Eclipse 1523	Eclipse 2029
Effective cutting area	15.5in x 26.5in	20.5in x 29.5in
Applicable paper	A3/A4/A5/B3/B4/B5	A2/A3/A4/A5/B2/B3/B4/B5
Machine dimension (L*W*H)	88in × 40in × 46in	110in × 43in × 46in
Package dimension (L*W*H)	89in × 44in × 58in	89in × 45in × 59in
Weight	662 Lbs	882 Lbs
Optional function	Roll Feeding Device	
Loading system	Vacuum Adsorption	
Cutting tools	Drag knife、Creasing wheel、Oscillating knife、Kiss cut	
Maximum cutting speed	1200mm/s (39in/s)	
Maximum cutting thickness	6mm	
Cutting accuracy	±0.1 mm (.004in)	
File format	DXF/PLT/PDF/HPG/HPGL/TSK/BRG/XML/CUT/OXF/ISO/AI/PS/EPS	
Connect port	USB/WLAN/WIFI	
Air pressure	75 PSI, 5 CFM, Moisture/Water/Oil Free	
Rated voltage	Single Phase - 208v/220v	
Power	30 Amp	30 Amp
Working condition	Temperature 50°F-80°F , Humidity 20%-80%RH	

The following aspects are defined uniformly and used to communicate with CUTWORX USA technical personnel and after-sales support engineers.

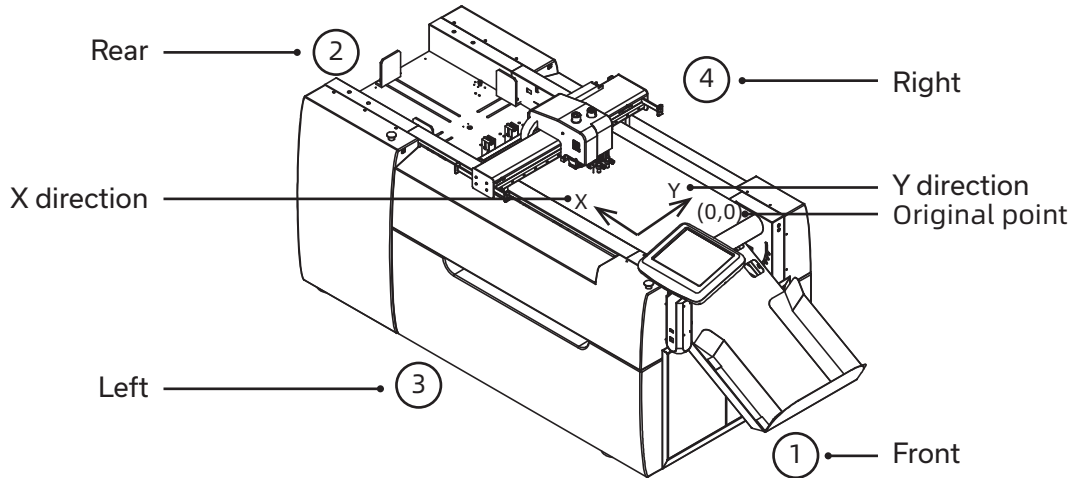

2. Machine Installation

2.1 Preparation Before Installation

2.1.1 Customer Installation Site Requirements and Environmental Requirements

Model	Eclipse 1523	Eclipse 2029
Required area	93in × 36in × 46in	102in × 40in × 60in
Indoor installation environment	Temperature 50°F-80°F , Humidity 20%-80%RH	
Power	Single Phase - 208v/220v 30 Amp	

2.1.2 Other Preparations

CPU: Intel(R) Core(TM) i5-10400 CPU @ 2.90Ghz, 16 GB RAM, 64-bit operating system, x64-based processor, Windows 10 Pro, 5 USB ports, mouse, keyboard, monitor.



2.1.3 Technician Requirements

The installer must be guided by CUTWORX USA technicians.

The installer is required to wear work gloves.

The installer must be familiar with the machine installation precautions, and have read and understood the installation instructions.

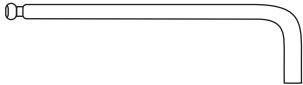
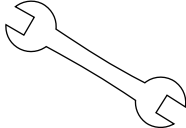
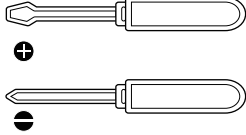
2.2 List of Installation Tools

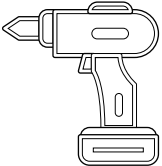
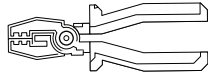
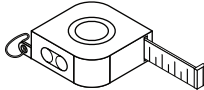
 <p>Allen key(2mm、6mm) Used to install EOT blades and collecting device</p>	 <p>Wrench(14mm、18mm) To adjust the feet level</p>	 <p>Screwdriver(cross, flat) Connect the communication line</p>	
 <p>Laser level Used to adjust foot level</p>	 <p>Electric drill(8mm sleeve) Used to unpack the box</p>	 <p>Pliers Used to remove the transport fixture</p>	 <p>Roll ruler Used to measure installation space</p>

2.3 Unpacking Instructions

2.3.1 Unpacking inspection and Notice

2.3.1.1 Unloading of Packages

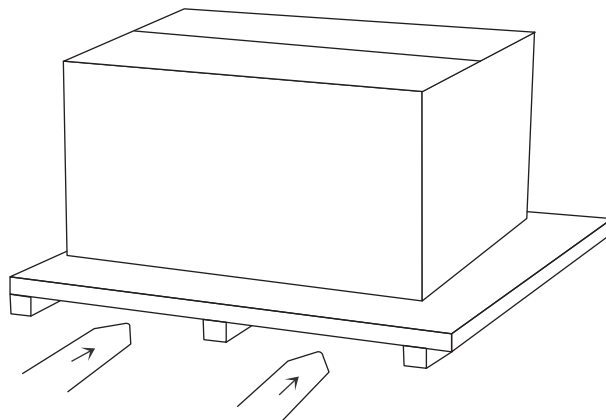

2.3.1.2 Check Before Unpacking

Before unpacking, please make sure that the packing box is not damaged or exposed to rain. Otherwise, please contact CUTWORX USA Support.

2.3.2 Unpacking Inspection and Notice

2.3.2.1 Remove the Screws of the Packaging Box

The packaging box is fixed by 8mm screws. When disassembling, use the corresponding size tool to remove the top and side plates.

2.3.2.2 Removal of Bottom Plate

- ⊙ Remove the bottom plate's fixing device to separate the equipment from the bottom plate.
- ⊙ First, remove all small moveable parts in the packaging box, including cables, collecting device, etc.
- ⊙ Disassemble the lower cover on both sides of the Eclipse.

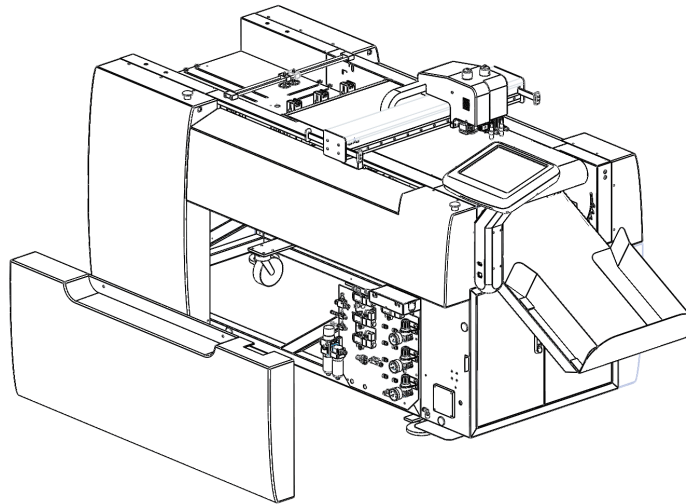

- ⊙ Remove the screws that bolt the leveling feet into the wood pallet. There are 8 total.

2.3.2.3 Discharge the Machine

Remove the Eclipse from the packaging box.

- ⊙ Remove the wooden board on the front side of the packaging box and place it as shown in the figure on the next page to build a slope.

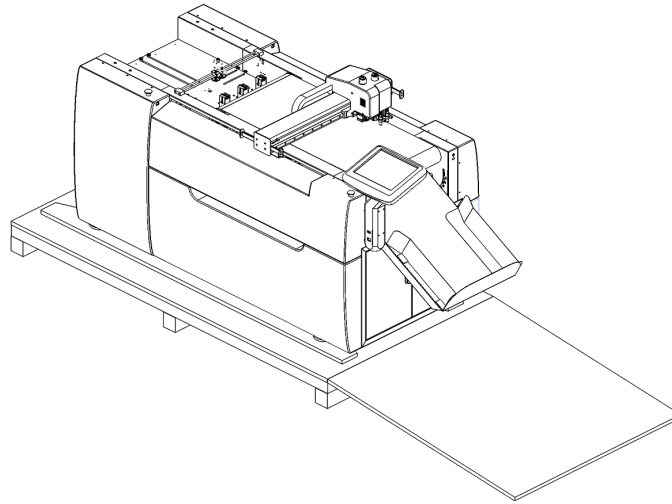

© Raise all the leveling feet of the Eclipse and make all the wheels of the machine land. At this time, care should be taken to prevent the Eclipse from slipping off the bottom plate.

The Eclipse is equipped with universal wheels which can move on flat surfaces. Make sure to raise the leveling foot bolt before using the wheel and height difference less than 20mm.

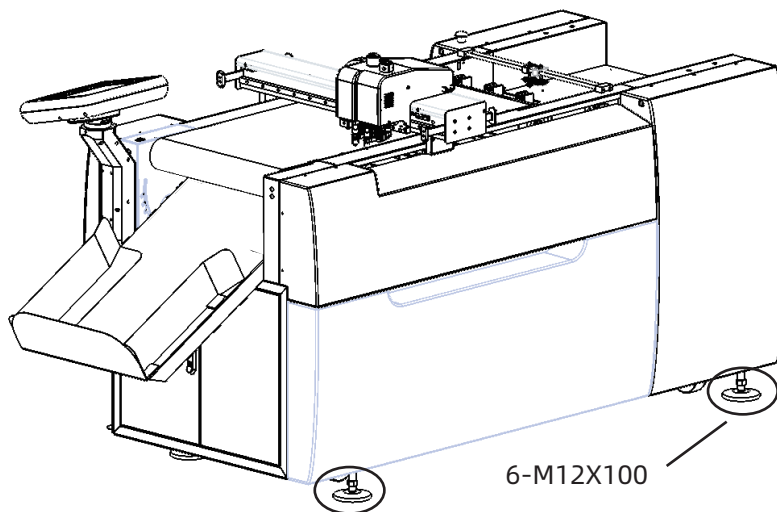

2.3.3 Installation of Equipment

2.3.3.1 Installation of Collection Device

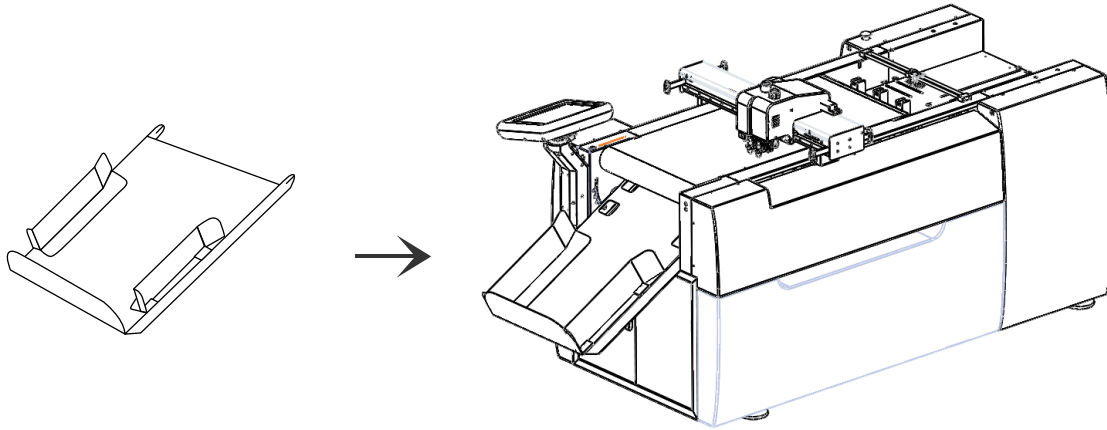

2.3.3.2 Installation of Air Compressor

Place air compressor under the table or use use in house air, plug power connection in and connect air tube from machine to compressor.

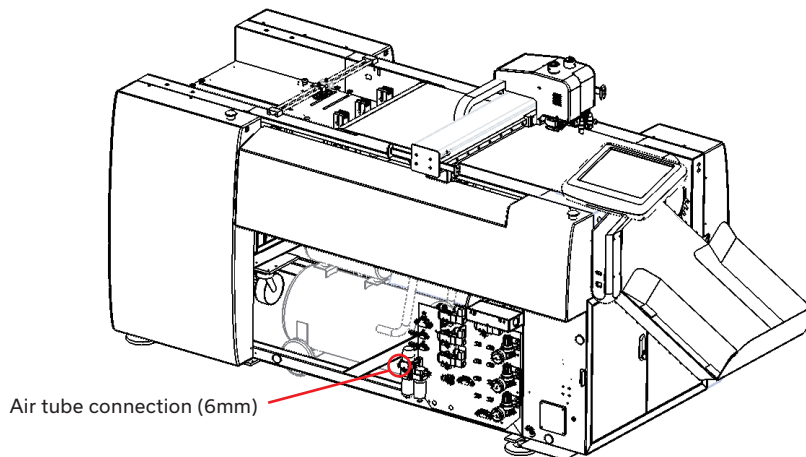

2.3.3.3 Connection for Power

Connect power cable to power input socket of the Eclipse and then connect the power plug to the power supply socket. Refer to site survey for electrical questions or specifications. Contact CUTWORX USA support if there are any questions.

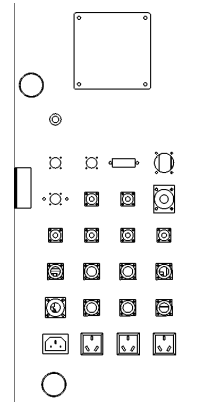
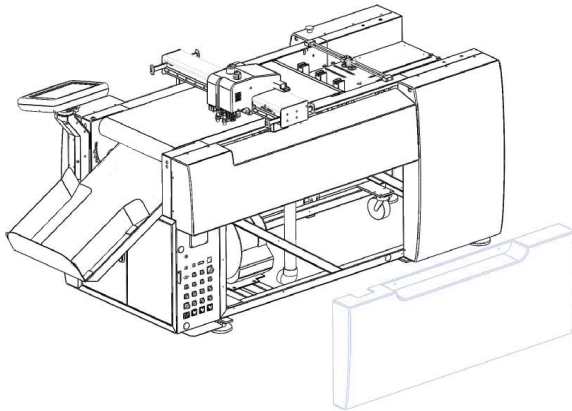

BKL19P: PC communication

PK07P: EOT power supply

PK08P: Tool control

PK09P: Y origin, z origin, EOT control

PK11P: suction solenoid valve and pressure solenoid valve control

PK12P: X origin

PK13P: Pause

PK14P: Emergency stop

PK15P: Power switch

PK16P: Air pump power supply

PK17P: Reversing solenoid valve control

PK18P: Anti-static solenoid valve control

PK19P: Lifting photoelectric control

PK20P: Lifting motor power supply

PK25P: Display communication (function not designed, not installed temporarily)

PK31P: Safety device control

PK30P: Lift button control

PK32P: Touch screen PC control

PK33P: Feeding motor power supply

DY3: ion emitter power

DY4: Air compressor power supply

DY5: Computer power supply

AC220VIN: 220V power input

2.3.4 Connection Between Machine and Computer

2.3.4.1 Connection of Communication Cable

Connect the CCM communication cable to the Eclipse in port labeled PK34P and tighten with screws. The connection port for this is located on the front facing panel next to collection device on pause button operator side. If using figure above, it would be the connection where a touch screen PC can be configured.

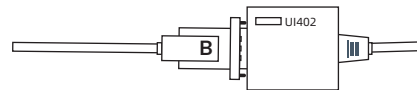

At the other end of the PK34P line is three lines shown in the figure below. All are respectfully marked with A/B/CCD. One USB serial converter will connect to line labeled B. A will not be used. Connect serial conversion of B to computer USB port

2.4 Computer Configuration

2.4.1 Windows Updates

Before beginning software installation, ensure Windows is not missing important security and quality fixes. Install all updates for Windows and Restart. After restart, ensure that no pending updates are ready to install or be installed.

Windows Update



Restart required

Your device will restart outside of active hours.

Your device is missing important security and quality fixes.

2021-08 Cumulative Update for .NET Framework 3.5 and 4.8 for Windows 10 Version 20H2 for x64 (KB5004331)

Status: Pending restart

2021-08 Cumulative Update for Windows 10 Version 20H2 for x64-based Systems (KB5005033)

Status: Pending restart

Intel Corporation - SCSIAdapter - 17.9.6.1019

Status: Pending restart

Restart now

Schedule the restart

[View optional updates](#)

View Optional updates and proceed to download and install all updates available. Restart after completion and check if any additional driver updates are available.

Optional updates

Choose the updates you want and then select Download and install.

Driver updates

If you have a specific problem, one of these drivers might help. Otherwise, automatic updates will keep your drivers up to date.

FTDI - USB - 8/16/2017 12:00:00 AM - 2.12.28

Dell, Inc. - Firmware - 0.1.4.1

Intel Corporation - Display - 27.20.100.9664

Download and install

2.4.2 Driver Updates

Navigate to device manager and check each COM & LPT port for updates. Also, check USB drivers for updates.

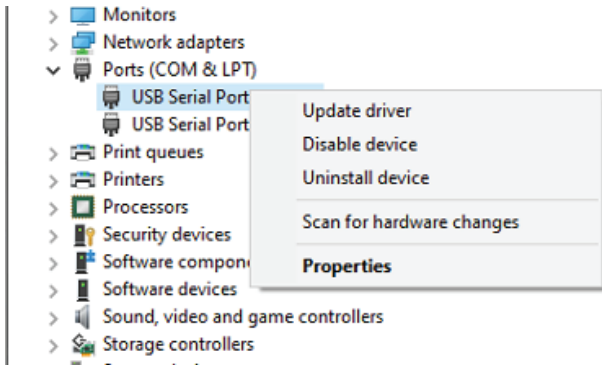

2.4.3 Windows Boot Configuration

2.4.3.1 Disabe Secure Boot

Hold Shift and and restart the computer.

Navigate to Troubleshoot and then click Advanced options.

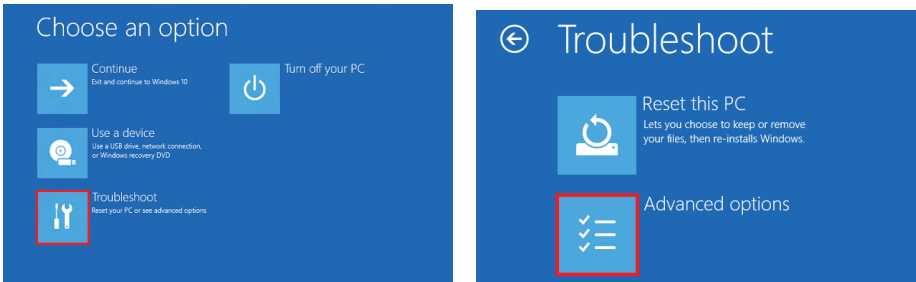

Select UEFI Firmware Settings and from the drop down click Secure boot and Secure Boot Enable. Turn Secure Boot off by unchecking the box labeled Secure Boot Enable on the left. Apply and Exit.

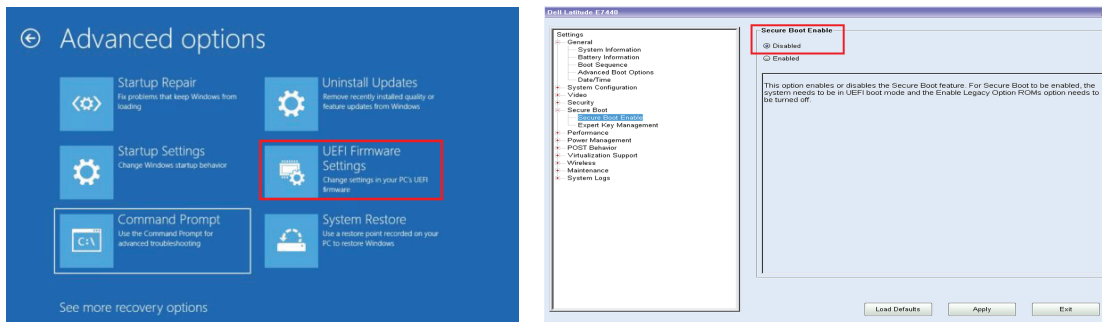

2.4.3.2 Disable Driver Signature Enforcement

Hold Shift and and restart the computer.

Navigate to Troubleshoot and then click Advanced options.

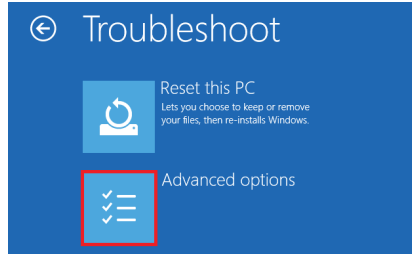
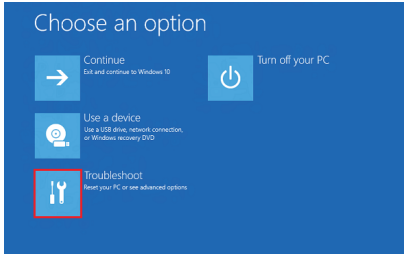

Select Startup Settings and restart.

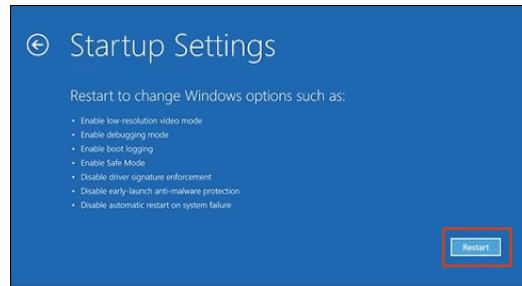
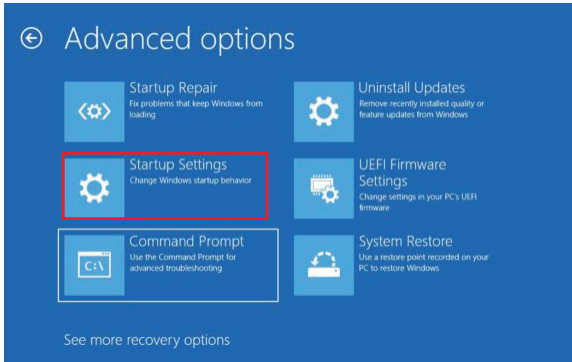

Click option 7, Disable driver signature enforcement.

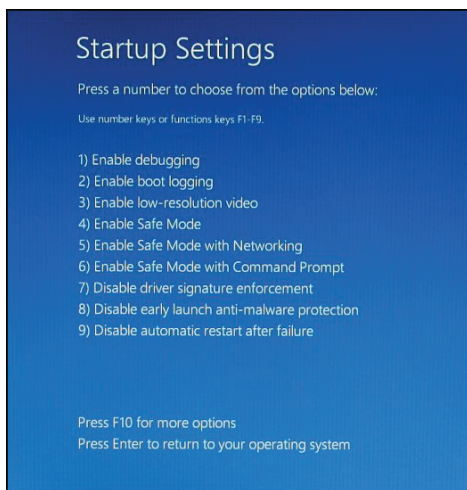

Boot normally.

2.5 Eclipse Software Suite Installation

2.5.1 Folder Directory Setup

Navigate to the OS (C:) Drive and create a new folder "Eclipse Software Suite".

Name	Date modified	Type	Size
Apps	2/23/2021 11:44 AM	File folder	
Dell	2/23/2021 12:00 PM	File folder	
Drivers	2/23/2021 11:17 AM	File folder	
Eclipse Software Suite	8/31/2021 11:23 AM	File folder	
Intel	10/18/2021 11:49 AM	File folder	
PerfLogs	12/7/2019 3:14 AM	File folder	
Program Files	10/21/2021 12:34 PM	File folder	
Program Files (x86)	10/21/2021 12:34 PM	File folder	
Users	8/31/2021 11:17 AM	File folder	
Windows	10/18/2021 2:50 PM	File folder	
RedisStoreInfor	11/1/2021 12:39 PM	Configuration sett...	1 KB

Create two folders inside the Eclipse Software Suite folder named "Cut Control Software" and "Design Manager"

Name	Date modified	Type	Size
Cut Control	8/1/2022 5:09 PM	File folder	
Design Manager	8/1/2022 5:09 PM	File folder	

2.5.2 Cut Control Software Installation

Double-click the installer for Cut Control.

First, the development environment is automatically installed. After completion of Microsoft updates, click agree to continue installation.

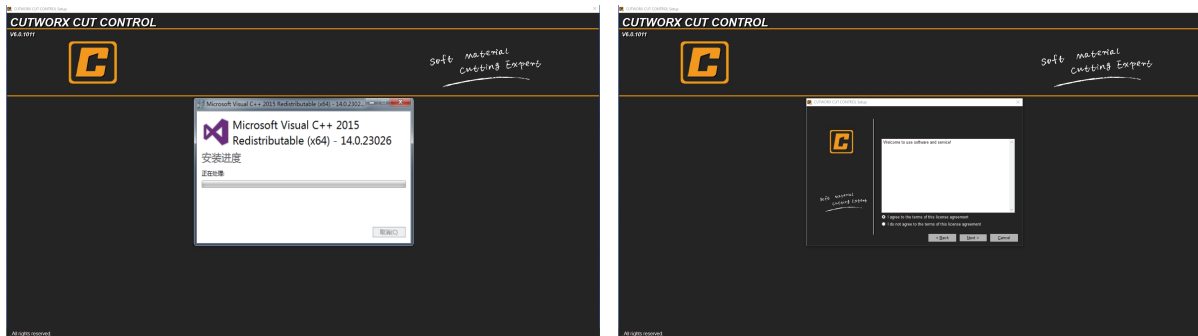

For encryption type, select either WIBU or Sentinel depending on license key. Sentinel is the black USB license key and WIBU is the silver USB license key.

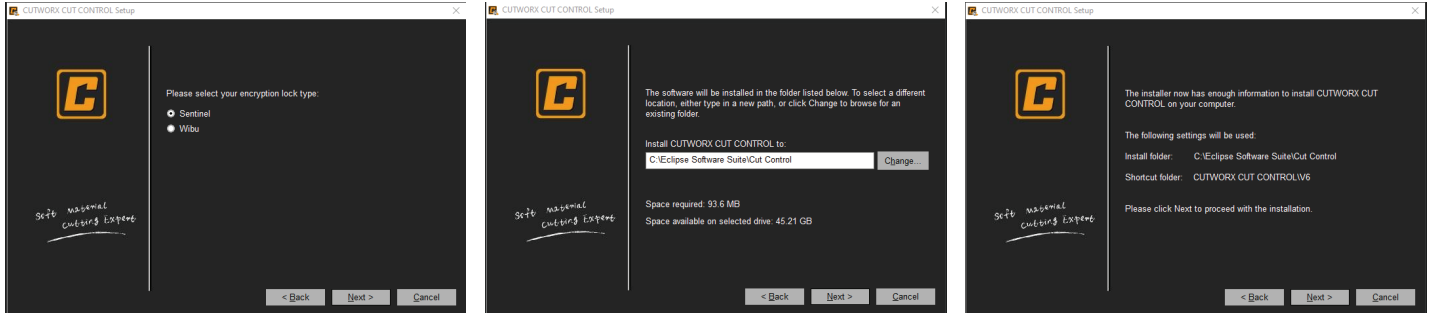

Install Cut Control Software to C:\Eclipse Software Suite\Cut Control Directory created in previous steps. Then select next on following menus to complete installation.

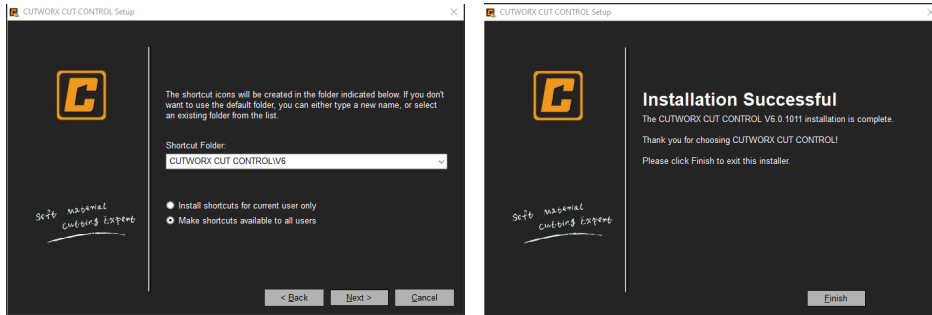

2.5.3 Design Manager Software Installation

Double-click the installer for Design Manager.

First, the development environment is automatically installed. After completion of Microsoft updates, click next to begin installation.

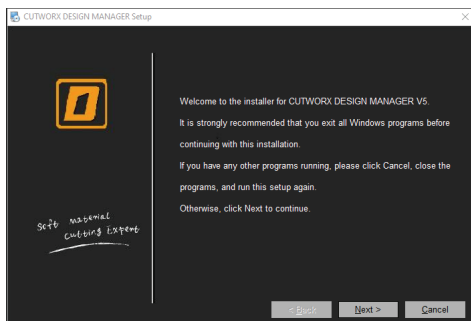

For encryption type, select either WIBU or Sentinel depending on license key. Sentinel is the black USB license key and WIBU is the silver USB license key.

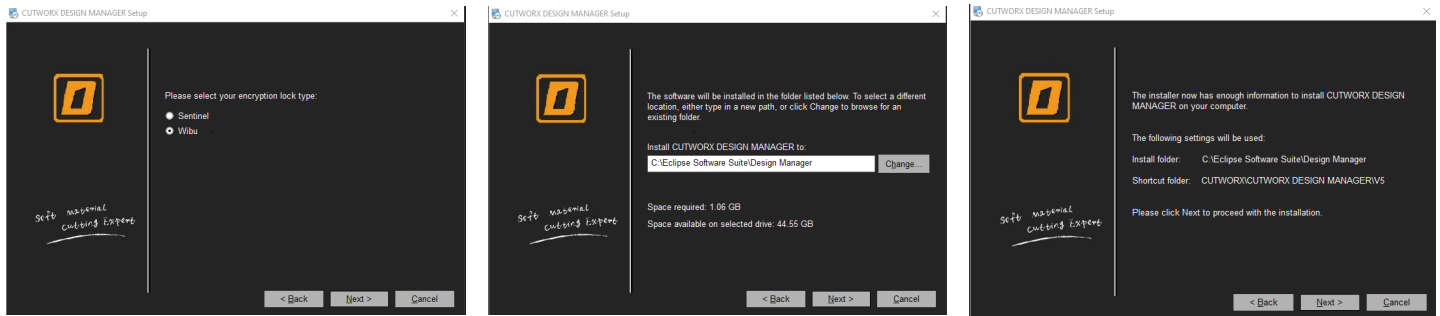

Install Design Manager Software to C:\Eclipse Software Suite\Design Manager Directory created in previous steps. Then select next on following menus to complete installation.

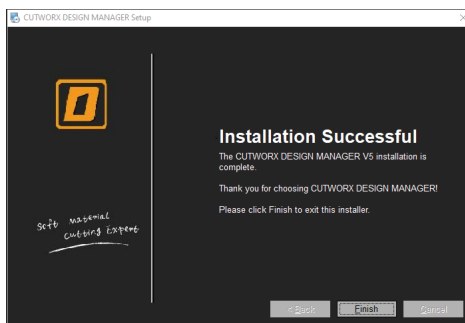

2.5.4 Configuring Admin and Security Privileges

2.5.4.1 Design Manager Properties

Right click and select properties on Design Manager icon on desktop. Enable the setting to run the program as administrator. Then navigate to Security and give full control permissions to all user groups. Click apply to each and exit.

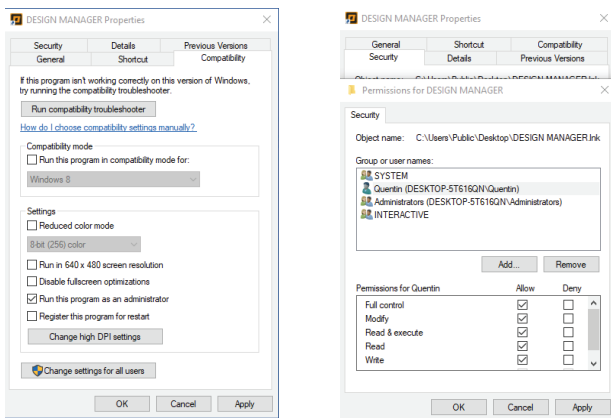

2.5.4.2 Cut Control Properties

Right click and select properties on Cut Control icon on desktop. Enable the setting to run the program as administrator. Then navigate to Security and give full control permissions to all user groups. Click apply to each and exit.

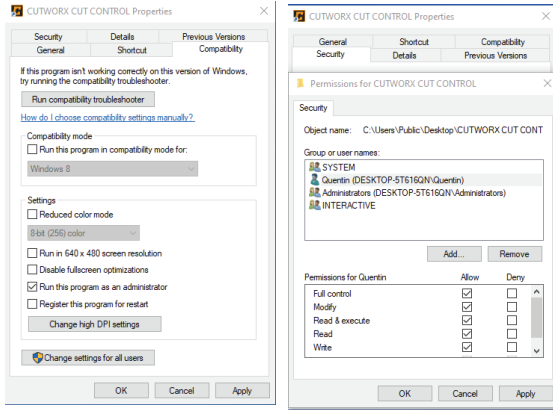

2.6 License Key Software Installation

Insert USB license key device into computer USB port.

2.6.1 CodeMeterRuntime Installation

Execute installation of CodeMeterRuntime application to install CodeMeter Control Center.

***Only use this program if license software key USB is silver.**

2.6.2 iEcho Sentinel Software Installation

Execute installation of iEcho Sentinel Update application to install Sentinel Control Center.

***Only use this program if license software key USB is black.**

Note: Sentinel may require installation of HASPUserSetup. Execute the installation if prompted after completion of iEcho Sentinel Control Center.

If software license key is not inserted when launching CUTWORX Software Suite, the following error will appear:

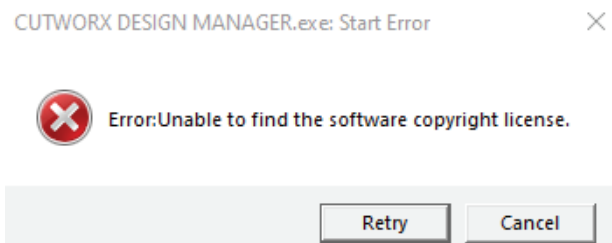

2.7 Pre-Boot Configuration

2.7.1 Power Supply Voltage Confirmation

Use a multimeter to check power supply voltage and confirm readings for 208v/220v.

2.7.2 Hardware Check

Manually push the beam and Eclipse head module to confirm whether or not there is abnormal noises.

2.7.3 Air Pressure Confirmation

Locate the air barometer for the Eclipse. The pressure requirement is 0.6MPa. To increase or decrease pressure, simply pull cap of barometer upward, then twist clockwise or counter to adjust to 0.6MPa. Once set, press downward on the cap to lock.

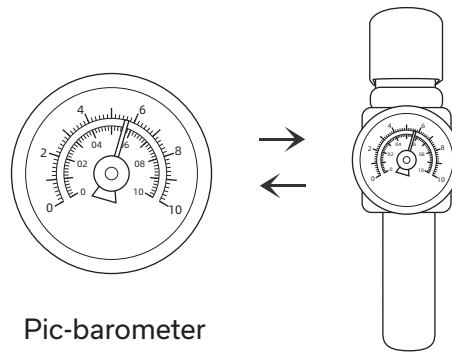

Pic-barometer

2.8 Booting the Eclipse

2.8.1 Booting Sequence

Press the power switch and a green ring will indicate the Eclipse is powering on. After a few seconds, the Eclipse tools in the head module along with the loading table will reset. After the reset, the Eclipse will be in the stanby state, and the communication state be confirmed in Cut Control Software once configured.

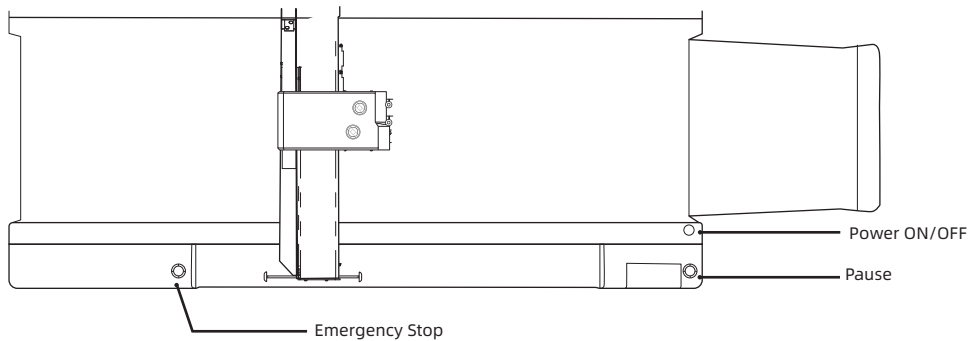

2.9.1.4 DK Tool Installation

Install DK tool into the insert in the frame of the Eclipse head module. Once inserted, install the clamps to hold in place and then tighten the screw to lock in place.

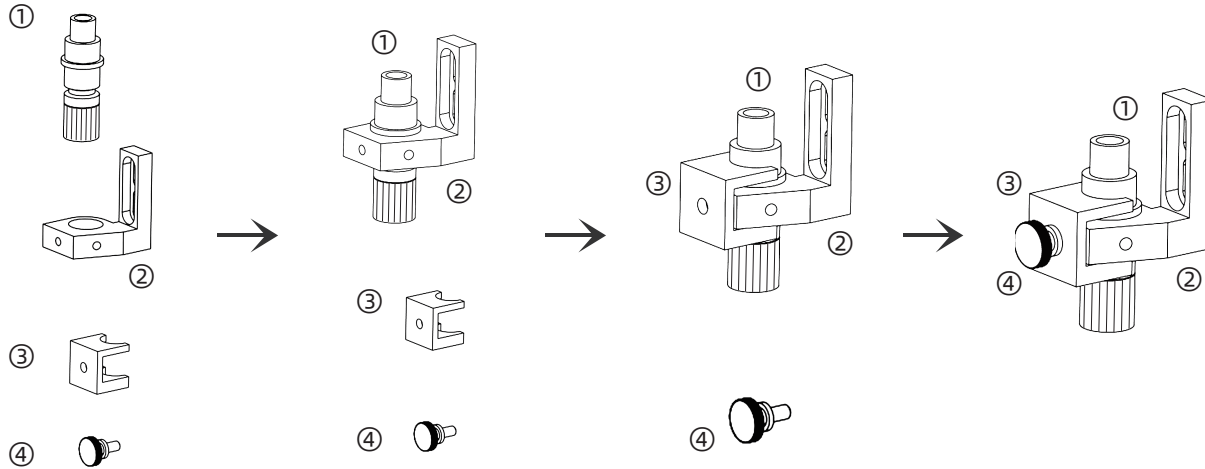

DK1 is located on outside tool holder on the Eclipse head module. Inset the red tip 1.5mm DK tool holder here.

DK2 is located on inside tool holder on the Eclipse head module. Inset the black tip 0.9mm DK tool holder here.

2.10 Feeding Device

2.10.1 Feeding Device Operation

After the device has powered on, the loading table can detect presence or absence of materials through infrared sensor detection via the material detect sensor located on the base of the loading table. When materials are covering the sensor, the table will rise and when materials are removed, the table will lower. The table will rise to meet the position of the height detection sensors. After material feeding, the loading platform will drop and rise to compensate for material being fed.

2.10.2 Usage of Feeding Device

Align the material forward and fix the magnetic plates to hold material in place.

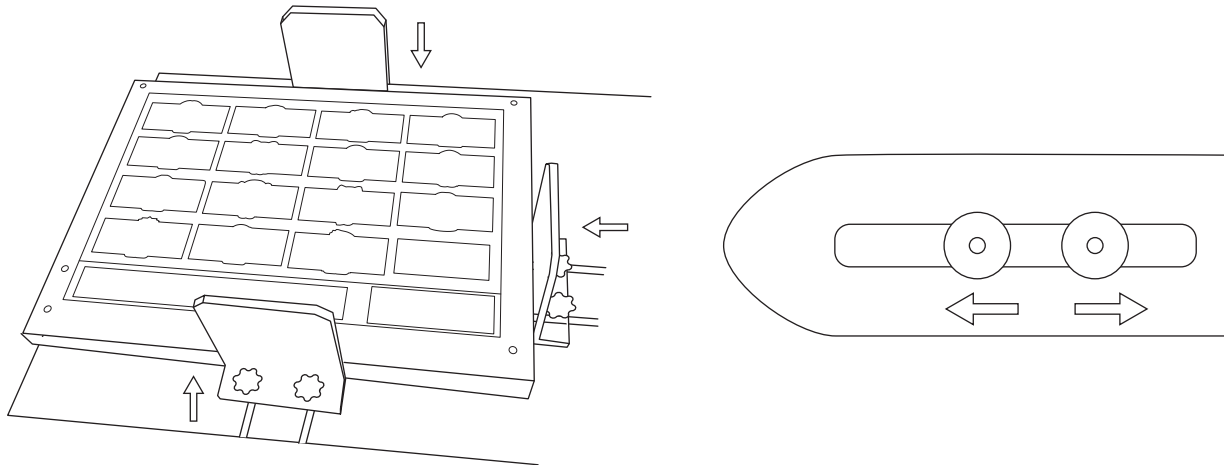

Adjust the length of the material separators to the proper position. The extension length is about 3-8mm.

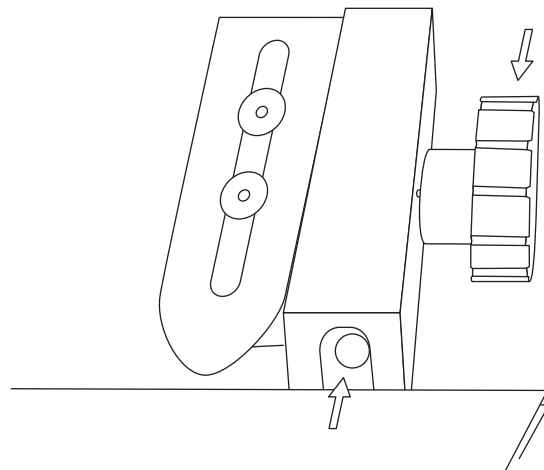

2.11 Suction Device

2.11.1 Working Principle of Suction Device

The suction device uses suction cups to grab materials. The vacuum system is operated through a vacuum pump and when materials are grabbed, the valves opens to connect the vacuum pump with the suction cup's pipeline.

2.11.2 Positioning of Suction Cups and Materials

Depending on material types and thickness, the height of the feeding table can adjusted by pressing the "UP" or "DOWN" button on the Eclipse.

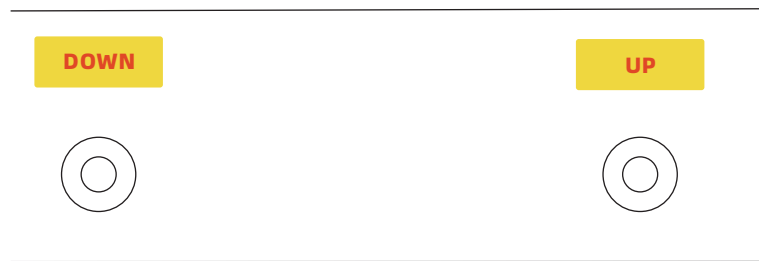

For air-impermeable materials, the loading table should be adjusted to the highest position. When the suction cup is grabbing the material, the suction cup should be in contact with the material.

For air-permeable materials, the height of the loading table should be appropriately lowered and distnaced between the suction cup and the material should be about 1-2mm.

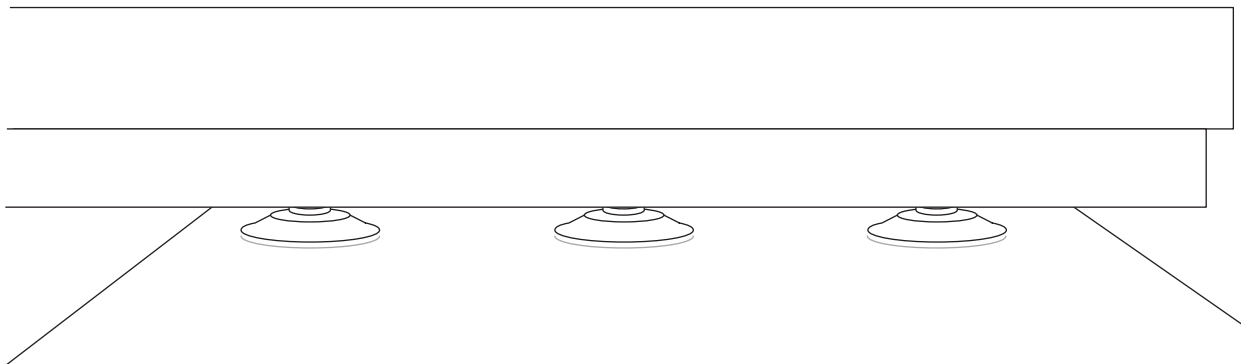

3. Eclipse Software Configuration

3.1 Design Manager Configuration

3.1.1 Cut Control Software Link

Opening CUTOWRX Design Manager for the first time will prompt the follow error:

"<<CUTWORX CUT CONTROL>> Linked path is incorrect!"

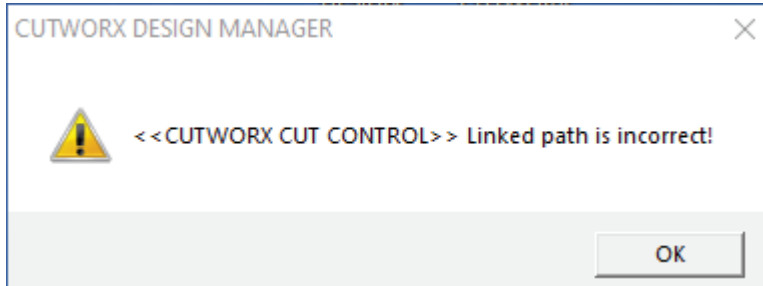

In Design Manager application, select Settings from the top tool bar and locate the option for Start CUTWORX CUT CONTROL.

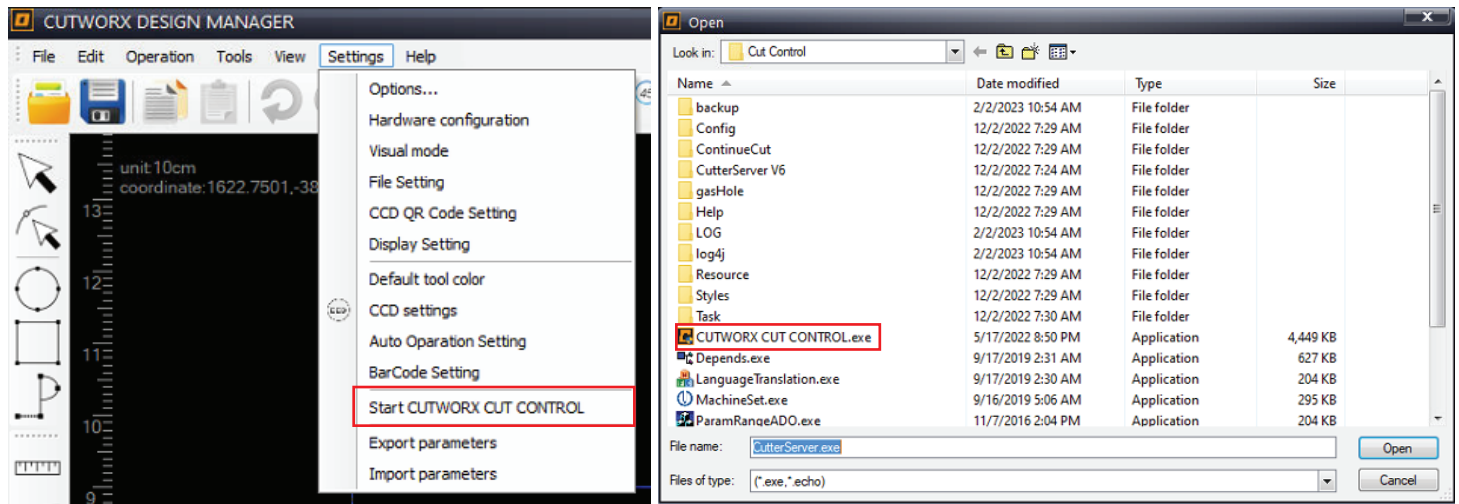

Linking the two programs will allow each to communicate with one another. When opening Design Manager, Cut Control will also open now.

3.1.2 Camera Hardware Configuration

3.1.2.1 CCD Camera Configuration

Click Settings in the top toolbar and from the drop down menu select Hardware configuration.

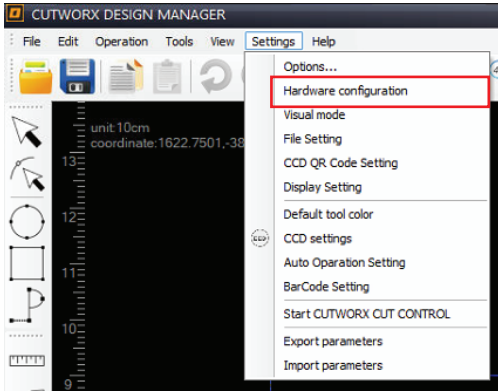

Select PK for model and for the output device select USB Camera. Click refresh button to update the camera name list.



From the new Camera name list, select AV to USB 2.0. Enable the check box for Image. From the drop down for image list, select DS610. Apply the changes and OK to submit. A restart of Design Manager will be required.



3.1.2.2 Visual Settings Configuration

After the software restart, proceed back to Settings, then click Visual mode.

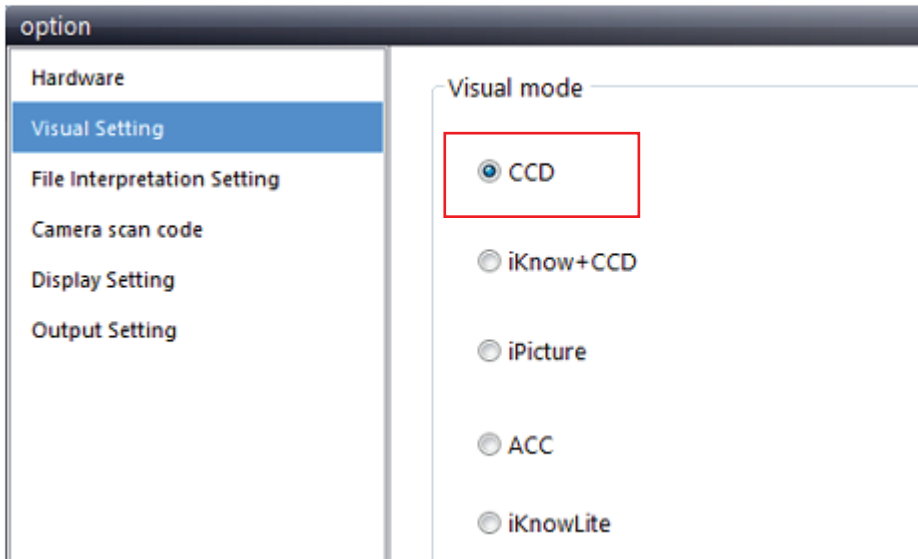

Make sure CCD is selected from the Visual mode options.

3.2 Cut Control Software Configuration

3.2.1 Serial Port Configuration

NOTE: It is important to ensure air compressor is on and connected to the device.

Open Cut Control Software. From the toolbar options, select Configuration(T) and from the drop down menu, click Serial Configuration(C).

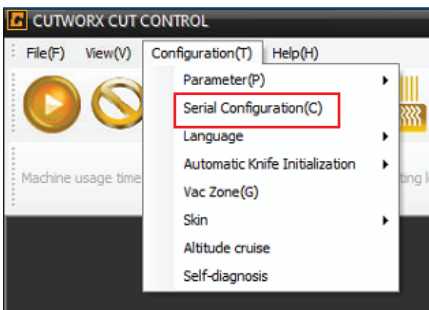

Click Autodetect to automatically assign COM ports to correct Serial No. If this does not work and the error DSP could not connect remains, manually assign COM connections until the Serial port.COM lights up green and control of the machine is accessed.

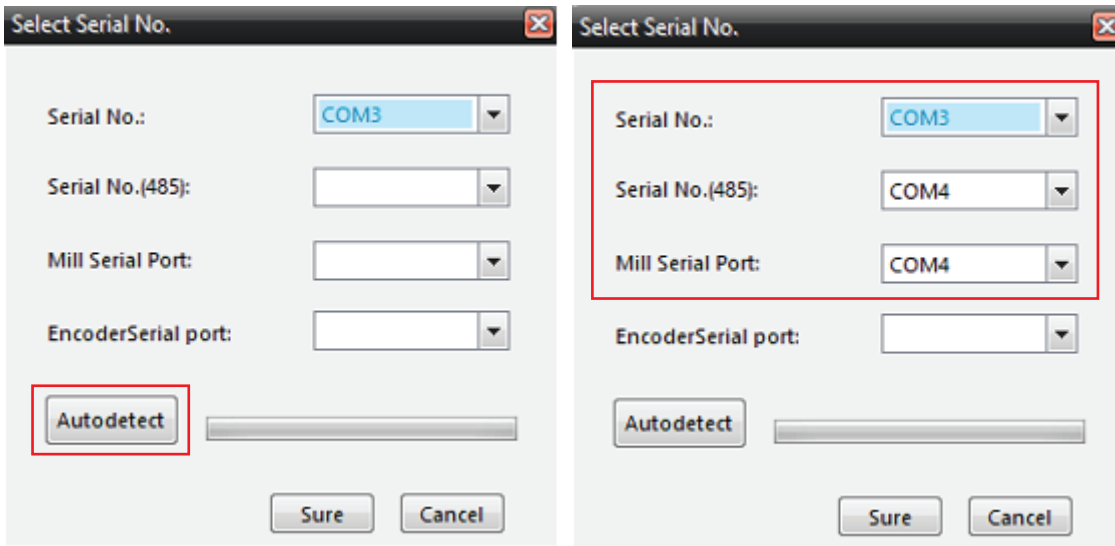

Click Sure to submit changes and if properly setup, the communication status of CutterServer Serial port.Com will be displayed in green and the machine head can be moved using the arrow keys on the computer keyboard indicating the machine communication is normal.



NOTE: Once properly connected to Eclipse, the gantry will change position to home origin, be sure to clear any obstacles in the path of reset. You may be prompted to allow acces to networks, be sure to select both private and public networks.

3.2.2 Cut Control Tool Bar Configuration

3.2.2.1 ABCommToolBar Setting Configuration

In Cut Control Software, right click on the following set of icons to open ABCommToolBar Settings.

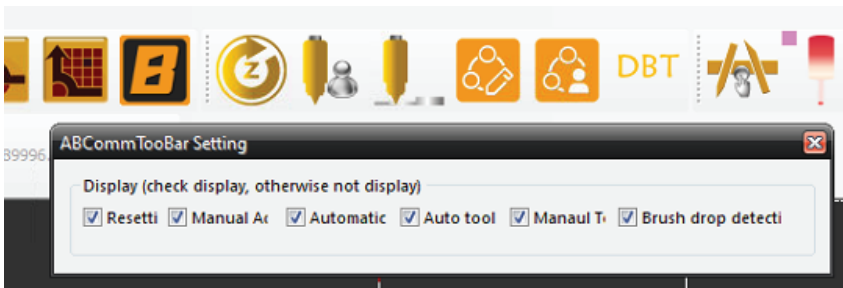

Unselect each option listed to remove from the toolbar as these functions are not available on the Eclipse 1523/2029 models.

In Cut Control Software, press CTRL+SHIFT+ALT+C on the keyboard to open the command options for the Eclipse.

The command settings are password protected. Input password "echocut" when prompted by the following screen and hit enter:



Change tabs to Commands and look for the following icons:

Collecting

PK One Button Tool Change

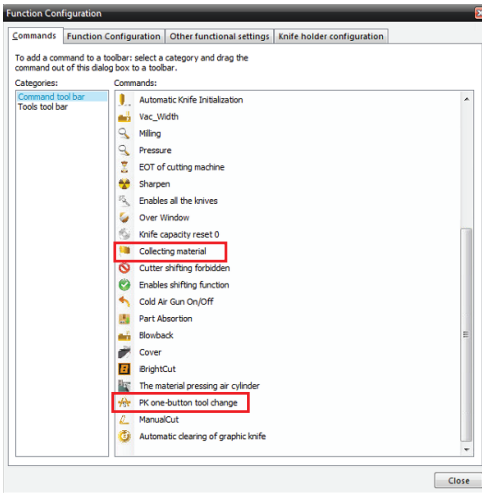

Each of these will be selected and dragged onto the top toolbar with icons present.

You can also reorder or remove by clicking and dragging an icon.

See image below and copy completed list.



3.2.2.2 Cut Control Command Functions Configuration

Switch tabs to Function Configuration and copy the following settings and shown in the image below:

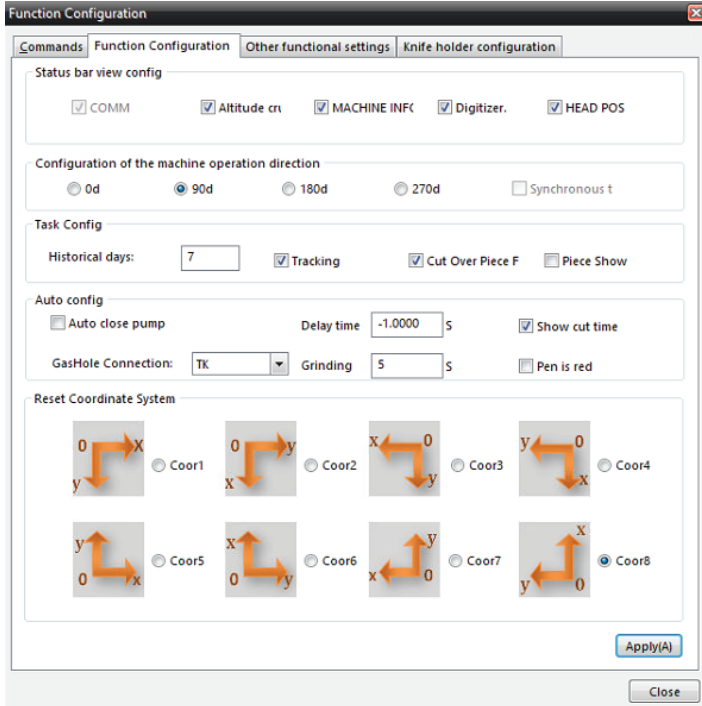

Click Apply when done.

3.2.2.3 Cut Control Knife Holder Configuration

Switch tabs to Knife Holder Configuration. By right clicking on a tool we can disable it from being used. The Eclipse only uses certain tools, so we disable the ones that will be used to eliminate confusion for operators. Copy the following image and close when complete. The yellow triangle image with an exclamation mark means the tool is disabled.

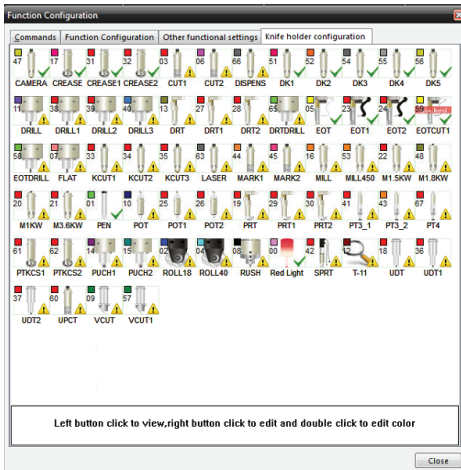

3.3 CCD Camera Calibration

3.3.1 CCD Camera Calibration Configuration

3.3.1.1 Inserting CCD Test Calibration Data

Open CUTOWRX Design Manager and right click in working area layout and select CCD offset calibration under the test insert test data category of the drop down menu. This will insert a cross mark on the layout preview, a layer will also be created in the layer setup.

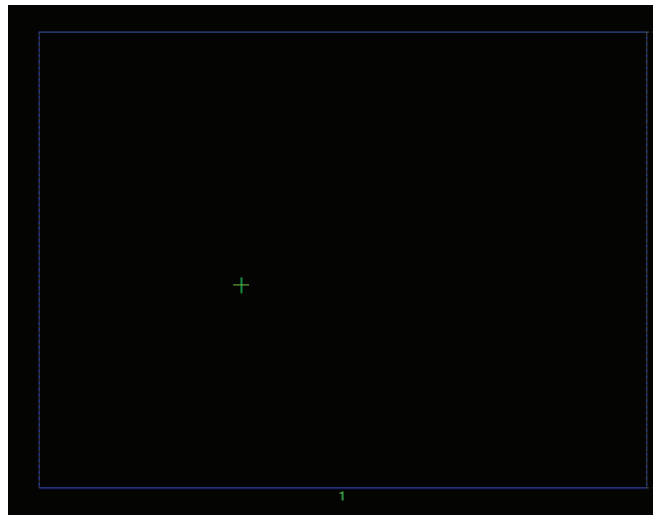
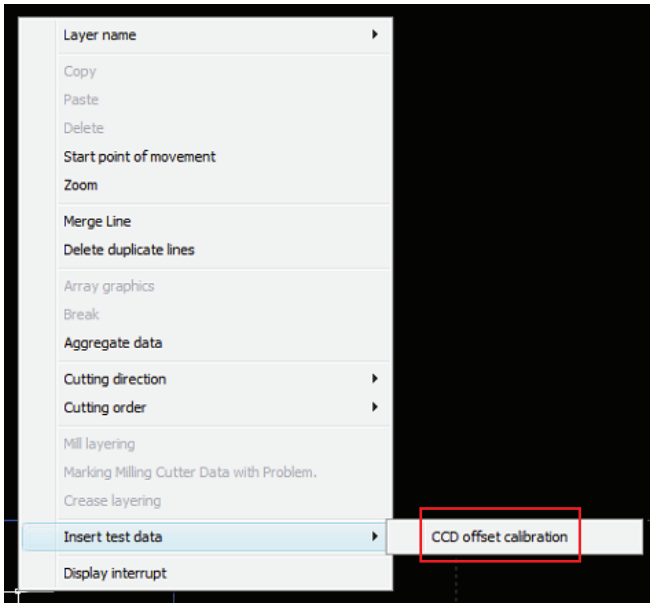

3.3.1.2 Tool Configuration

Double click the new layer that was created to open the layer properties.

Under the method tab, select DK.

Under the second tab selection, assign DK1.

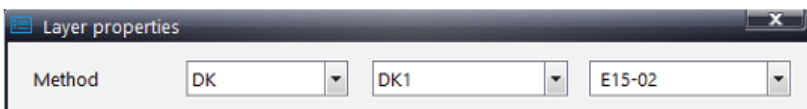
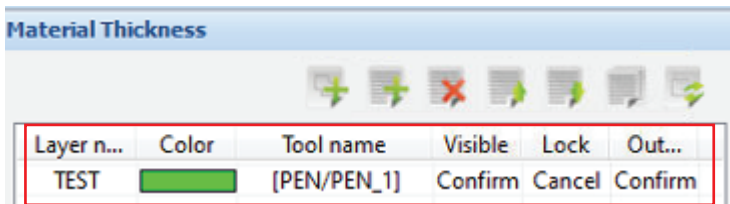

3.3.1.3 Output Settings Configuration

Under Output settings, input 0 for Cut times and from the drop down menu for OutputMode, select Direct.

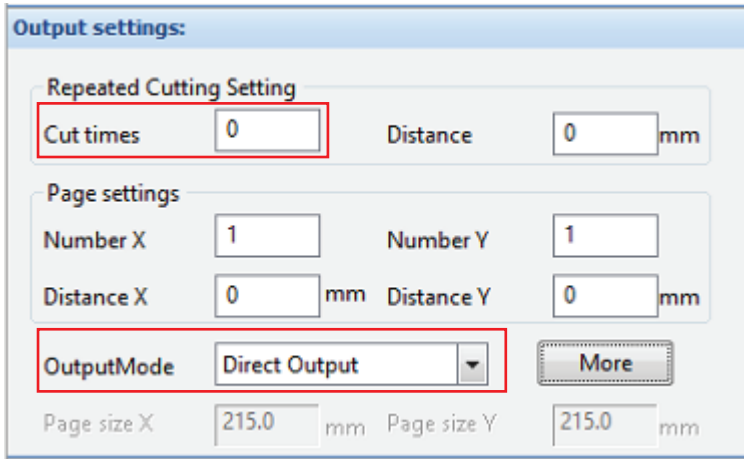

3.3.1.4 Material Loading

Place a blank white sheet of paper onto the loading device table. Once the loading table has stabilized at proper height, manually feed the material onto the conveyor belt by selecting the feed icon. The vacuum will automatically activate to hold material firm. If the vacuum does not activate, select the vacuum icon to power it on.

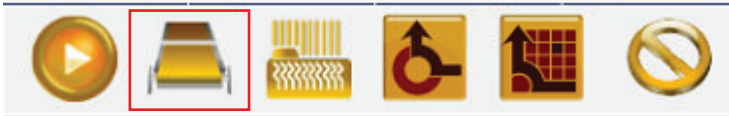

3.3.1.5 Cross Cut Procedure

Switch to Cut Control Software and select the redlight icon.



Then select the return to origin icon



The Eclipse head module will reset to home position. Once movement has stopped, select the DK1 tool. The head module will move slightly.



Lastly, select the start icon in Design Manager and the Eclipse will proceed to cut the cross mark generated earlier into the material.

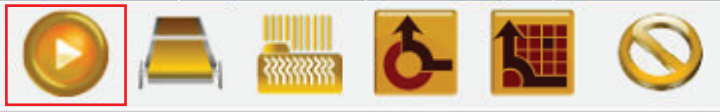

3.3.1.6 Offset Measurement

After completion of cutting, in Design Manager, locate the CCD camera button in the top tool bar. Select it to bring up the camera feed.



Using the arrow keys on the keyboard, navigate the camera feed over the cross mark that cut. Camera is located behind red laser light on Eclipse head module. Position the camera so that the cross hair of the camera feed is centered on the cross mark cut intersection as shown in image below.



Below the camera feed is a section labeled, Current Coordinates. Click the button Get Coordinates. An X and Y coordinate will generate. Right click on either set of numbers and from the drop down, select set the X/Y offset.

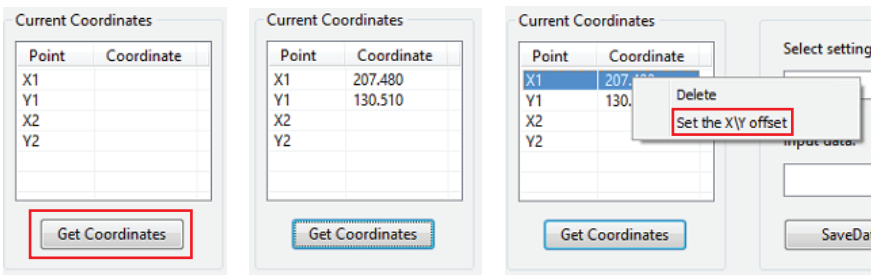

A prompt will appear for X/Y offset. Enter 200 for each box for the Eclipse 1523 and 400 for each box for the Eclipse 2029 model. Press confirm when done.

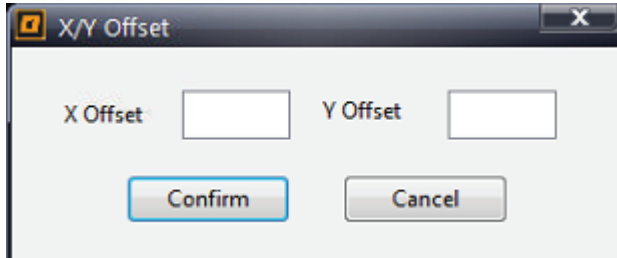

3.3.2 Registration Mark Calibration

From the select setting item drop down menu, select the Marks radius(mm) setting. Input the correct mark size for dection. If using 3mm registration marks, input 3.00 and save data.

It is recommended using 6mm filled black circles for registration marks.

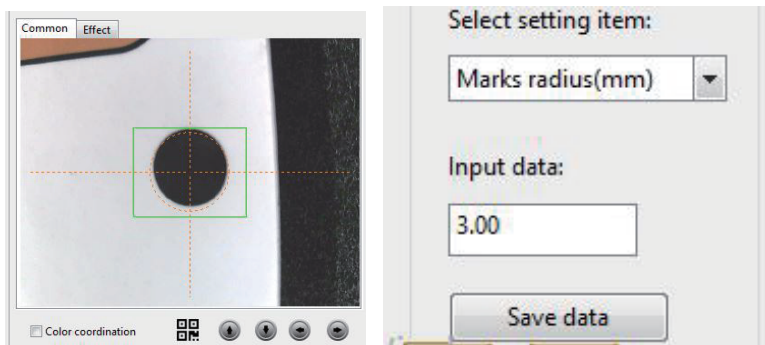

3.3.3 Collecting Device Configuration

3.3.3.1 Collecting Device Test

To test the collecting device, locate and select the collect icon in Cut Control Software.



Run the roller at least 3 times to ensure motor starts and functions properly.

Also, test with vacuum powered on to test blowback function.

3.3.3.2 Collecting Device Fixes

Issue: Collecting device attempts to rotate, but a load noise is heard and conveyor belt does not rotate.

Resolution: Check the air intake barometer and ensure pressure it set to 0.6MPa. If the pressure is less than this, the blowback suction does not work properly and the belt will remain and place and can not rotate.

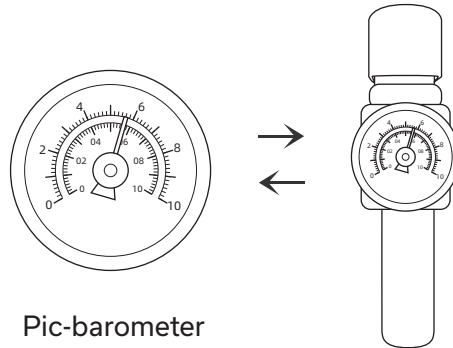

Issue: Collecting device attempts to rotate but does no fully rotate.

Resolution: Ajust the tension of belt and motor by using an allen key to loosen or tighten the collecting motor.

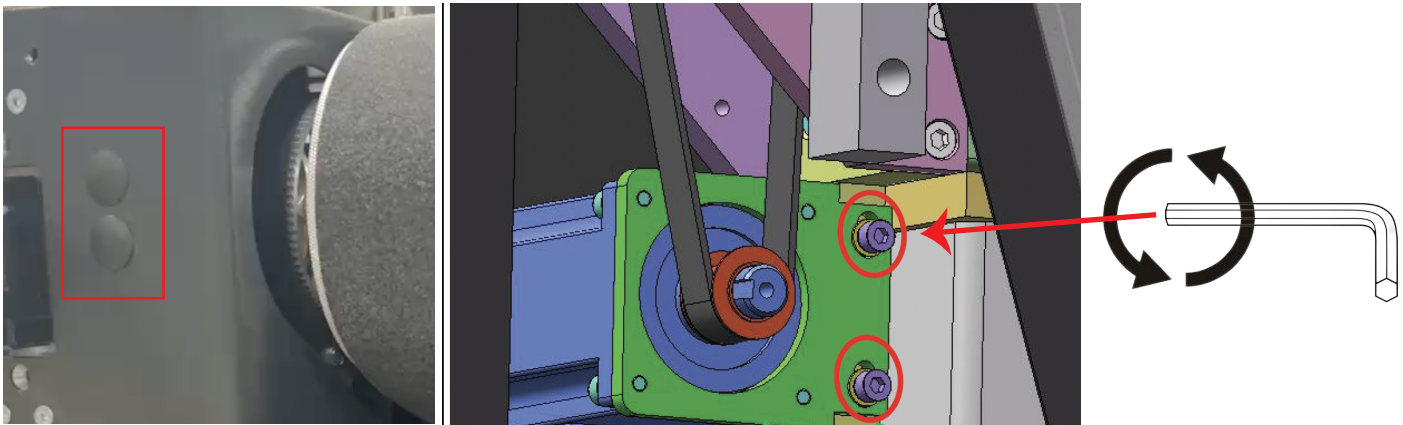

Remove covers to expose screw adjustments for belt tension. Insert an allen key and turn clockwise or counter clockwise dependent upon current status of belt tension.

If there is a lip in the belt near the front edge, tighten the belt by turning the allen key clockwise.

Be sure to adjust both sets of screws (4 total) evenly.

4. Offset Cutting Test

4.1 EOT Tool Configuration

4.1.1 EOT Blade Introduction



E19-2



E19-3

4.1.2 Installation of EOT Blade

In Cut Control Software, select the EOT tool holder and then select the PK one button tool change icon. The following window will be prompted:

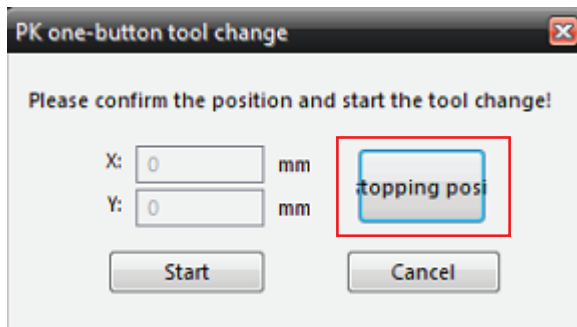

When using for the first time, it is required to set the stop position. Start by selecting the Stopping position option and move the gantry head to a suitable position. It is ideal to mode the Eclipse head module over the side barrier so the EOT is exposed as the tool will need to drop.

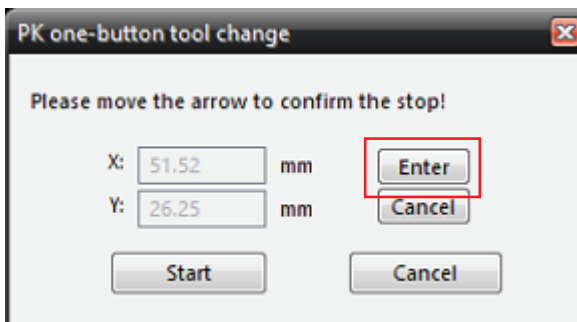

Press Enter to save the location of the position. At this point you will only to select start and the EOT will automatically move into position.

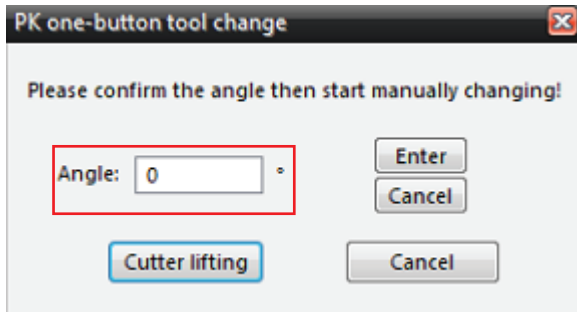

The EOT will move into position when clicking Start and drop the tool holder down. In this state, operator can remove the pressure plate and replace the blade. If the tool angle needs to be adjusted, adjustments can be made to the Angle and saved by selecting Enter. Select Cutter lifting to save the changes and raise the EOT tool holder back up. Click complete to finish EOT blade change.

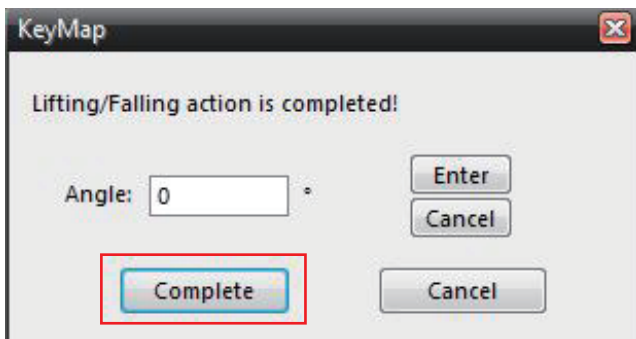

4.1.3 Material Press Plate Installation

- ① press plate buckle is connected with the cylinder rod.
- ② The press plate slider is connected with two positioning roots
- ③ Tighten the fixing screws

***Note: Pay attention to prevent damage to the blade during installation.**

4.1.4 Debugging of EOT Tool

Rotate the knob on the Eclipse head module manually. Rotating clockwise direction is rising and the counterclockwise direction is lowering. The knife can be dropped by manually pressing the knob to observe the depth of the knife.

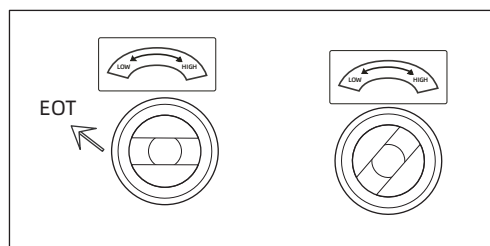

4.1.5 EOT Tool Configuration

4.1.5.1 Configuring Positive Blade Angle

Right click on EOT Tool in Cut Control Software. This will prompt the EOT tool parameters. Ensure direction to rotate is enabled and knife lifting angle is set to 45.00.

Parameter item	Value	Unit	Range Of Value
SOCKET3	EOT		
Positive angle of knife and X axis	215.000	limit	-360.000 ~ 360.000
Knife-up compensation	-0.500	mm	-30.000 ~ 30.000
Knife-down compensation	0.000	mm	-30.000 ~ 30.000
Knife lifting angle	45.000	limit	0.000 ~ 360.000
X,Y movement speed	0.010	m/s	0.010 ~ 2.000
Knife-lower speed.	89.999	mm/s	0.010 ~ 1000.000
Knife lifting speed	89.999	mm/s	0.010 ~ 1000.000
Movement acceleration	0.250	G	0.010 ~ 1.500
Setting acceleration	0.500	G	0.010 ~ 1.500
The maximum knife setting depth	15.178	mm	0.000 ~ 18.310
Waiting time before setting	10.000	ms	0.010 ~ 10000.000
Waiting time before knife lifting	10.000	ms	0.010 ~ 10000.000
Waiting time after setting	10.000	ms	0.010 ~ 10000.000
Waiting time after knife lifting	10.000	ms	0.010 ~ 10000.000
Direction to rotate	<input checked="" type="checkbox"/>		
The distance between former knife p	1.000	mm	-20.000 ~ 100.000
The distance between later knife poi	1.000	mm	-20.000 ~ 100.000
Eccentricity enable	<input checked="" type="checkbox"/>		
X eccentric distance	0.300	mm	-100.000 ~ 100.000
Y eccentric distance	0.500	mm	-1.270 ~ 1.270
Circle + Angle	0.000	limit	-5.000 ~ 5.000

Manually press the EOT knob on the Eclipse head module and rotate till the knife is showing but not touching the belt.

Next, engage the EOT tool by selecting the EOT tool in Cut Control Software then right click the EOT tool to bring up the EOT tool parameters screen.

Adjust the Positive angle until the blade angle cutting direction is facing the loading device where paper sits till it is fed onto the conveyor belt.

The blade should not favor a direction, but at a zero point facing back.

Apply the changes each time a new angle is set and the blade should automatically adjust. Once set, click apply and sure to save.

4.1.5.2 Configuring EOT Eccentricity for X & Y

Step 1: Start by right clicking on EOT tool in Cut Control Software, locate X and Y eccentric values. Input 0 for each. Apply and select sure to save.



X eccentric distance	0.000	mm	-100.000 ~ 100.000
Y eccentric distance	0.000	mm	-1.270 ~ 1.270

Step 2: Open Design Manager Software and right click in the working area layout. Locate the insert test data drop down and select the CCD test calibration. This will place a cross mark onto the layout preview.

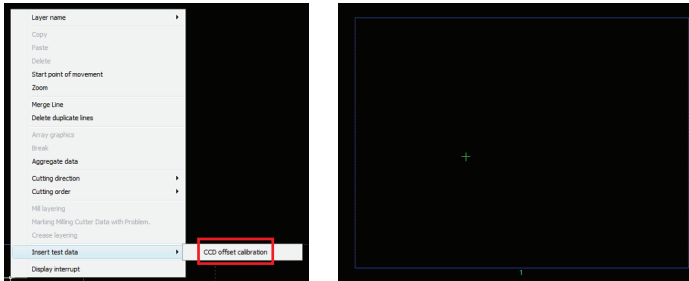

Step 3: Select the cross mark that is generated and press the "1" keybinding on the keyboard. This will move the cross mark into the origin point corner.

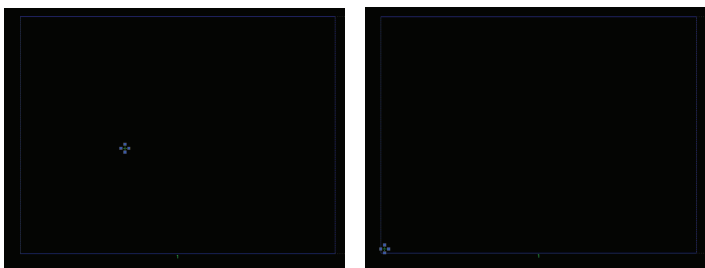

Step 4: In the generated layer for output, double click the test layer to open the layer properties. Assign CUT for the holder, EOT for the tool, and E19-3/E19-2 depending on blade choice for the blade.

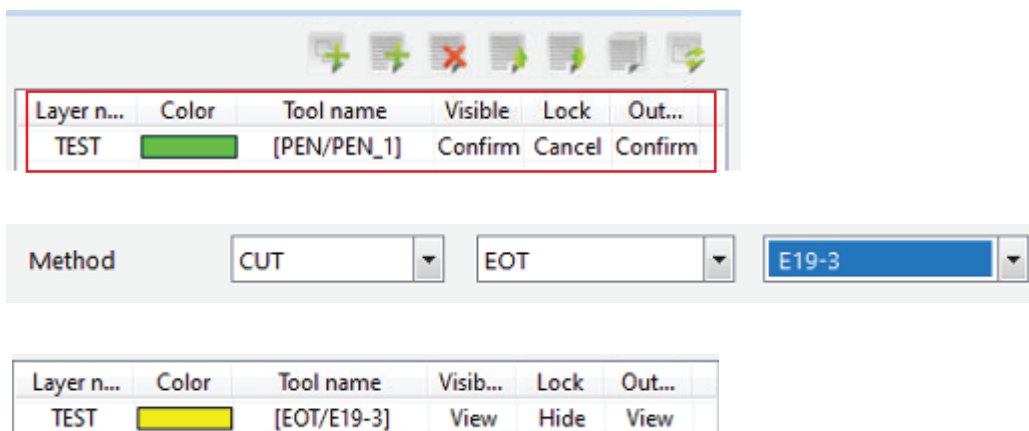

Step 5: Under Output settings, change to manual production mode and input 0 for cut time.

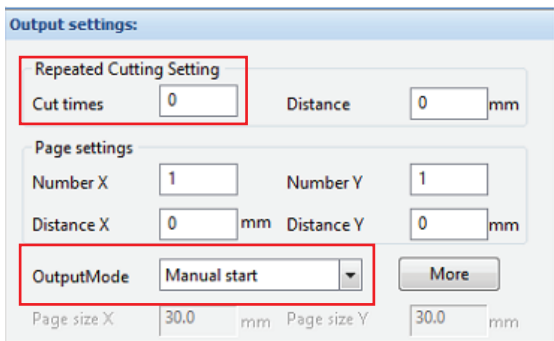

Step 6: Manually place a white sheet of cardstock onto the conveyor belt, ensure the gantry will not collide with the paper, square the sheet to the belt.

Step 7: Power the vacuum system on by selecting the vacuum icon, then select the start icon to send the cut file to Cut Control Software.

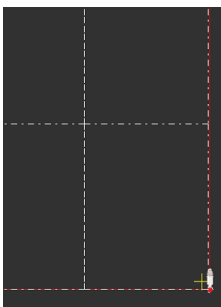

Step 8: In Cut Control Software, select the red light tool. The red light is shown on the conveyor belt under the Eclipse head module. The red light illuminating is now the start point for where the cut will begin. Navigate the red light over a spot on the sheet of material placed earlier.

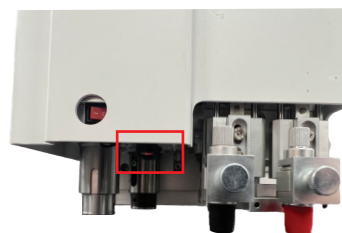

Step 9: Use the knob above the EOT tool to set the depth for the EOT blade. Manually press the knob downward to see set depth. Configure the blade to be able to cut the material fully through.

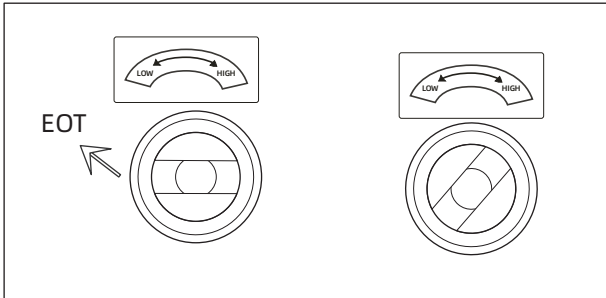

Step 10: When setup is complete, select the start icon in Cut Control Software and the Eclipse will process the cut file. When finished executing the cutting task, manually move the machine by double clicking in the layout preview in Cut Control Software or use the arrow keys to direct the gantry away to view the cut.



Step 11: The goal is to adjust the X eccentric value until the cut matches the below figure on the right side. The cut path should start and stop at the same end points evenly.

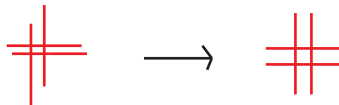

Adjust the X eccentric value in the EOT tool parameters until the ideal cut is achieved. Each time a value is changed, simply select the apply and sure buttons to save. Then select the relative origin button to bring the machine back to its last cut start point. move the machine over with the arrow keys and select the start icon again to repeat the cut file.

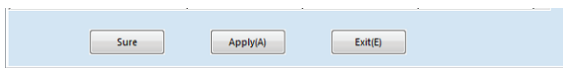

Step 12: Repeat the same steps for the Y eccentric value until the below figure on the right is achieved. The cross mark should cut start and stop and the same end points while cutting on the same path each direction.

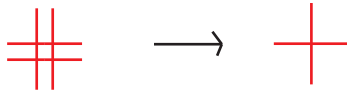

4.2 Calibration Test Cut File

4.2.1 Calibration Test Cut File Configuration

4.2.1.1 Calibration File Import

Open CUTOWRX Design Manager and select the file option in the top tool bar. From the drop down menu, select Open.

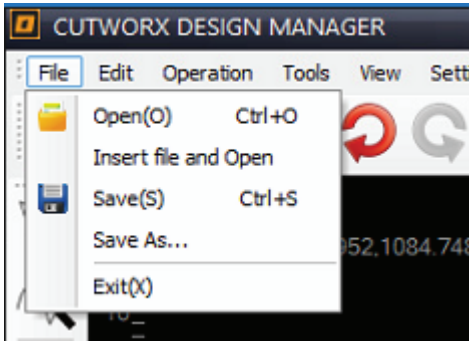

Open CUTOWRX Design Manager and select the file option in the top tool bar. From the drop down menu, select Open. The File open menu will prompt. Select the Eclipse 1523 Offset Test file and select the open option to import the cut file into Design Manager.

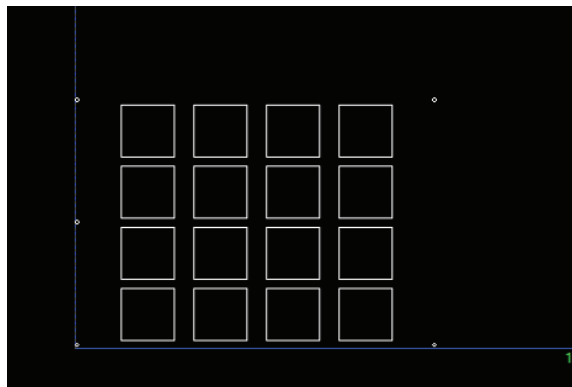
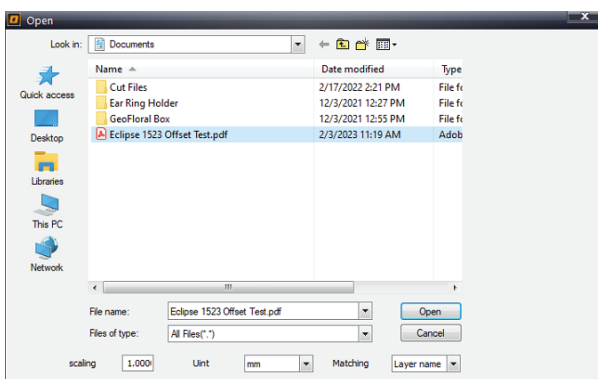

Print this sheet with no scale onto 13x19 cardstock material.

4.2.1.2 Tool Configuration

Under the layer order, select a layer to see vector lines assigned to the layer. Selecting layer 1 will select the registraion mark layer.

Layer n...	Color	Tool name	Visib...	Lock	Out...
Layer 1		[UNKNOW/]	View	Hide	View
Layer 2		[UNKNOW/]	View	Hide	View
Layer 3		[UNKNOW/]	View	Hide	View
Layer 4		[UNKNOW/]	View	Hide	View
Layer 5		[UNKNOW/]	View	Hide	View



Assign the CCD tool for the method under layer properties.

Layer properties

Method

Assign the following to each layer:

Layer 2 - DK / DK1 / E15-02

Method

Layer 3 - DK / DK2 / E15-01

Method

Layer 4 - CREASE / CREASE / CREASE_1

Method

Layer 5 - CUT / EOT / E19-3 or E19-2

Method

Layer n...	Color	Tool name	Visib...	Lock	Out...
Layer 1]Fast Contour Cutt	View	Hide	View
Layer 2		[DK1/E15-02]	View	Hide	View
Layer 3		[DK2/E15-01]	View	Hide	View
Layer 4		[CREASE/CREASE_1]	View	Hide	View
Layer 5		[EOT/E19-3]	View	Hide	View

4.2.1.3 Output Settings Configuration

Under output settings, change cut times to 0 and output mode to direct output mode.

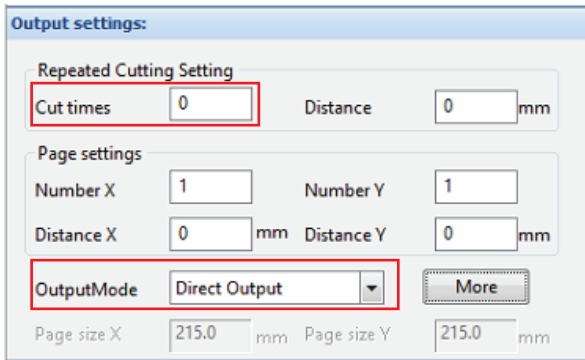

4.2.2 Start Calibration Sheet Cut

Turn the vacuum system on and select the start icon.

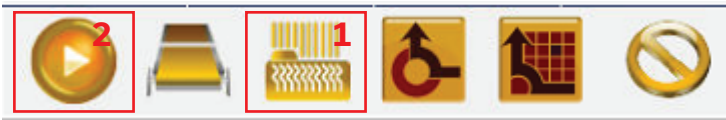

The CCD camera feed will appear. Navigate the camera to the first registration mark indicated by a red highlighted mark in the preview layout. Use the arrow keys on the keyboard to drive the Eclipse gantry and head module.

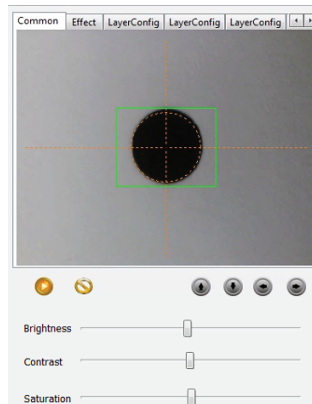
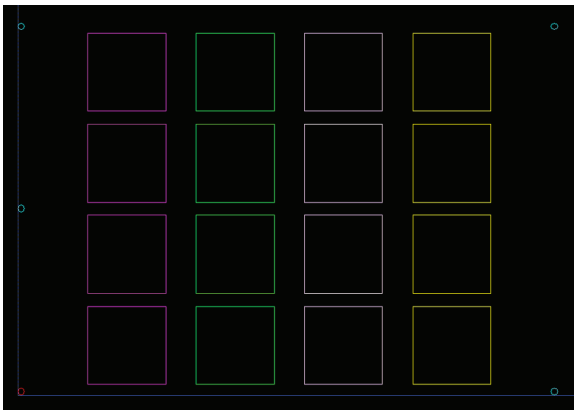

Once the registration mark is in view, select the start production icon located below the CCD camera feed screen.

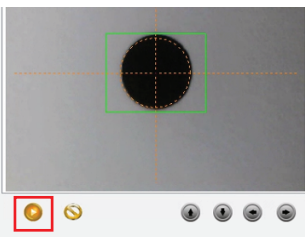

CCD camera will locate each registration mark and once complete, the cut file will be sent to Cut Control Software for processing.

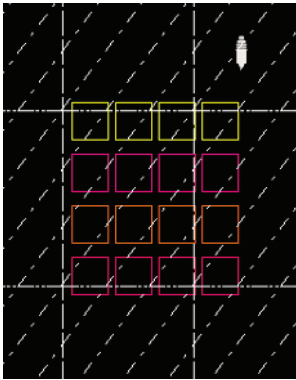

The cut file will process and each tool will be used. At completion of cutting, check where each tool has cut. Each tool should cut directly on the lines. If each tool is off in the same spot, repeat the camera calibration. If only a few tools or one tool is off, offset adjustments will be needed for the tool socket.

4.2.3 Tool Offset Adjustments

To adjust the offset for a tool, open Cut Control Software. Select the drop down for Configuration(T), then select Modification(P). Input password "echocut" when prompted and hit enter.

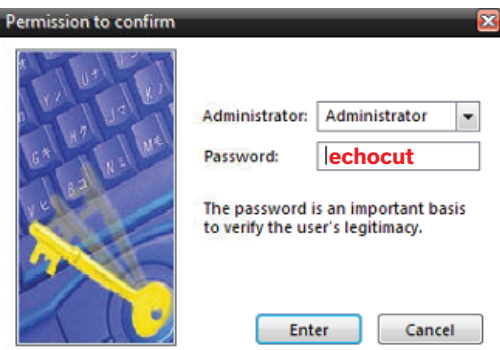
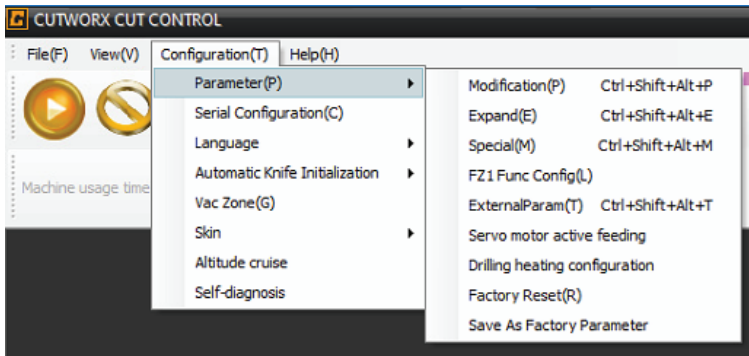

Scroll down until you locate socket type. From the drop down, select the socket that needs adjustment. The tool to the right will populate when changing sockets and new parameters will load.

Socket1		DK1		
Socket	X-axis offset	0.000	mm	-200.000 ~ 1000.000
	Y-axis offset	0.000	mm	-200.000 ~ 1000.000
	A knife and X forward	0.000	limit	-360.000 ~ 360.000
	Control mode	7		

For this example, the EOT tool is cutting at the below position in relevance to our printed die line:

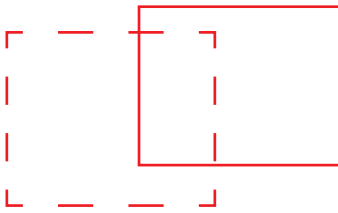

Socket3		EOT		
Socket	X-axis offset	135.070	mm	-200.000 ~ 1000.000
	Y-axis offset	88.930	mm	-200.000 ~ 1000.000
	A knife and X forward	0.000	limit	-360.000 ~ 360.000
	Control mode	1		

The X-axis offset and Y-axis offset will need to be changed. Measure in mm and input the change into these parameters.

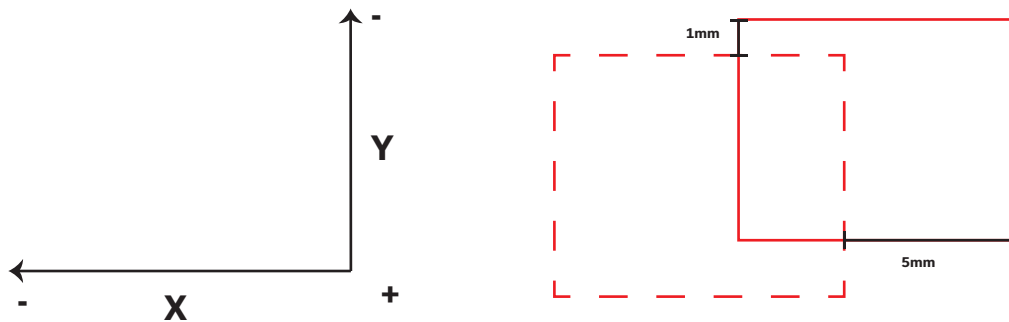

According to measurements, the X axis will need to be adjusted by 5mm in the positive direction. Add 5mm to the original 135.070 value to make the new value 140.070.

According to measurements, the Y axis will need to be adjusted by 1mm in the positive direction. Subtract 1mm from the original 88.930 value to make the new value 87.930.

Process the file to test the new offset. Be sure to click apply and exit to save the settings.

5. Support

5.1 TeamViewer Remote Support

5.1.1 Downloading TeamViewer

Visit <https://www.teamviewer.com/en-us/download/windows/>

Download the latest version for x64 bit operating system.

TeamViewer for Windows

- ⌕ Establish incoming and outgoing connections between devices
- ⌕ Real-time remote access and support
- ⌕ Collaborate online, participate in meetings, and chat with others

Download 64-bit Version

Download 32-bit Version

Or skip the download and connect [directly from your browser](#).

Available for Remote Access, Premium, Corporate, and Tensor license holders.

Current version: 15.38.3

5.1.2 Remote Support Request

Open TeamViewer application and locate the Allow Remote Control section. Copy the Your ID and Password.

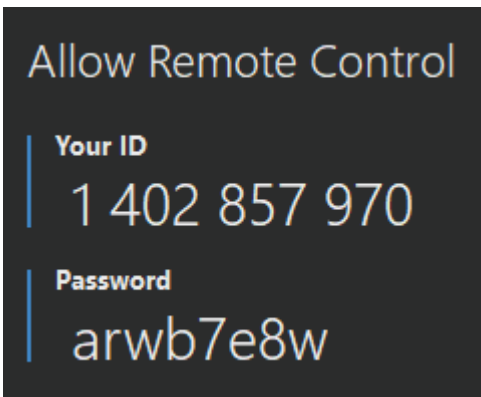

Contact a certified support technician for the Eclipse digital die cutters or email support@cutworxusa.com with a request for remote support with detailed information of the issue.

5.2 Troubleshooting

5.2.1 Communication Errors

5.2.1.1 Camera Failed to Connect

Issue: Camera is failing to connect when opening the CCD camera feed.

Resolution #1:

Open CUTWORX Design Manager. Navigate to the Settings page and locate the Hardware Configuration tab.

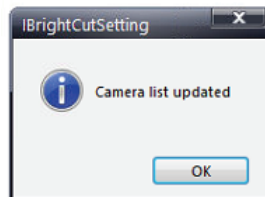
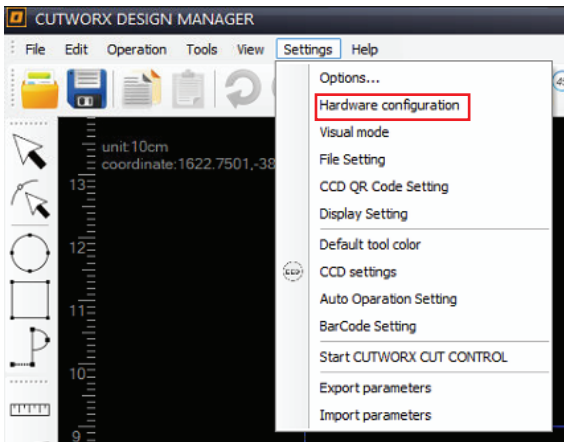

Refresh the connections, then assign USB Camera. From the Camera Name menu, select USB2.0 Camera.

Enable Image and select D610 option.

Resolution #2:

Change the USB port connection for the USB Video Grabber.
Once the change has been made follow steps of resolution #1.

Resolution #3:

Check and install all pending Windows updates.

Windows Update



Restart required

Your device will restart outside of active hours.

Your device is missing important security and quality fixes.

2021-08 Cumulative Update for .NET Framework 3.5 and 4.8 for Windows 10 Version 20H2 for x64 (KB5004331)

Status: Pending restart

2021-08 Cumulative Update for Windows 10 Version 20H2 for x64-based Systems (KB5005033)

Status: Pending restart

Intel Corporation - SCSIAdapter - 17.9.6.1019

Status: Pending restart

Restart now

[Schedule the restart](#)

[View optional updates](#)

View Optional updates and proceed to download and install all FTDI-USB Driver updates available along with other updates.
Restart after completion and check if any additional Driver updates are available.

Optional updates

Choose the updates you want and then select Download and install.

Driver updates

If you have a specific problem, one of these drivers might help. Otherwise, automatic updates will keep your drivers up to date.

FTDI - USB - 8/16/2017 12:00:00 AM - 2.12.28

Dell, Inc. - Firmware - 0.1.4.1

Intel Corporation - Display - 27.20.100.9664

Download and install

Resolution #4:

Disable secure boot and driver signature enforcement

Hold Shift and and restart the computer.

Navigate to Troubleshoot and then click Advanced options.

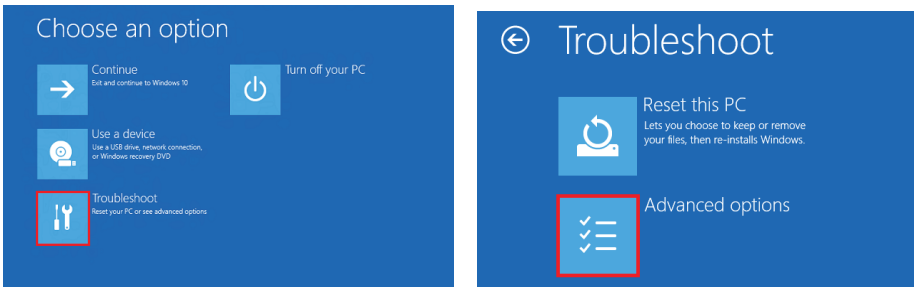

Select UEFI Firmware Settings and from the drop down click Secure boot and Secure Boot Enable. Turn Secure Boot off by unchecking the box labeled Secure Boot Enable on the left. Apply and Exit.

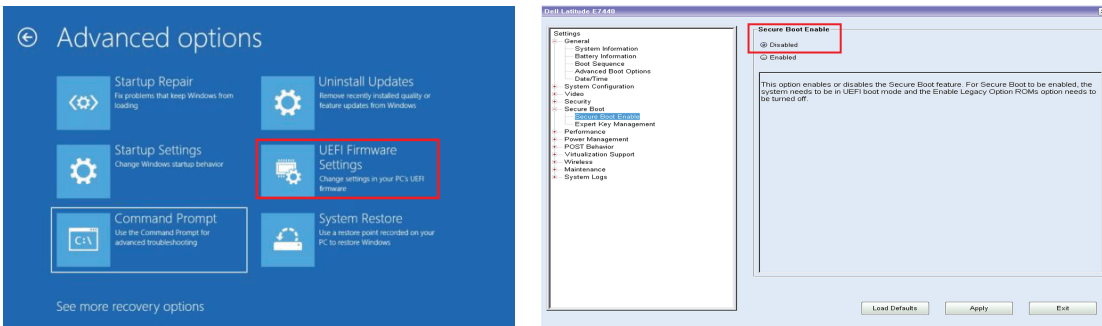

Hold Shift and and restart the computer.

Navigate to Troubleshoot and then click Advanced options.

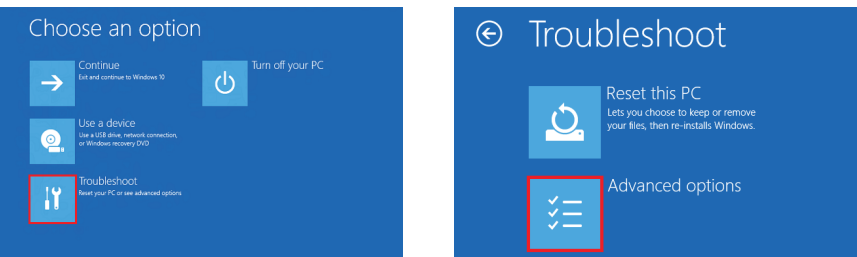

5.2.1.2 DSP Serial Connection Disconnect

Issue: When booting the Eclipse, the machine and software do not link/connect.

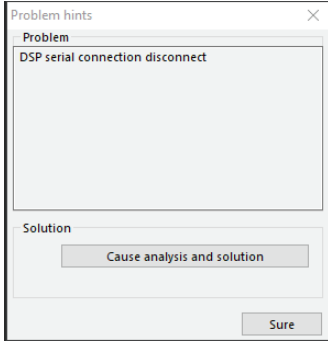

Resolution #1:

Check that the air compressor is turned on and functioning.

Air barometer should read 0.6MPa.

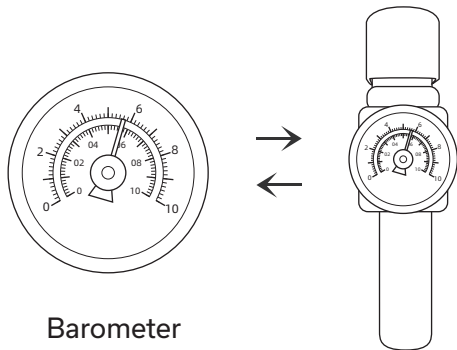

Barometer

Resolution #2:

Update Windows and Device Drivers.

Navigate to device manager and check each COM & LPT port for updates. Also, check USB drivers for updates.

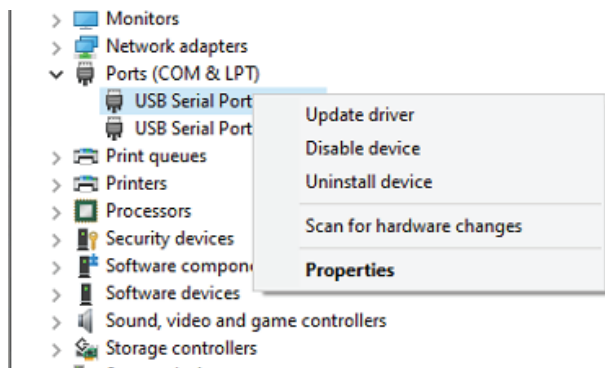

5.2.1.3 DSP Serial Connection Disconnect

Issue: Eclipse will not respond to movement directions in the software. An alarm code is prompted stating there is a barrier.

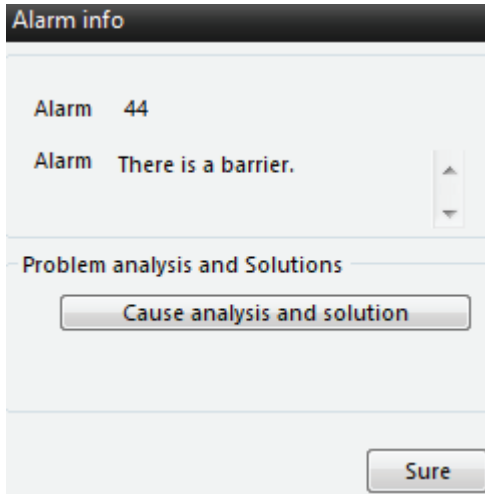

Resolution #1:

Remove any obstacles blocking side sensors of the Eclipse. Once removed, clear the error by selecting option Sure. Machine will home if during boot up procedure or will allow control again.

5.2.2 Loading Device Troubleshooting

5.2.2.1 Error: No Material

Issue: Loading device is not moving and reports an error in Cut Control Software stating no material.

Resolution #1:

Place material onto loading device. Ensure material is covering the eagle eye material detect sensor. Loading device will initialize.

5.2.2.2 Error: Waiting for PLC to be Ready

Issue: Loading device is not moving and reports an error waiting for PLC to be ready.

Resolution #1:

Loading device is in reset mode, wait for it to complete, then clear the error and try again.

Resolution #2:

Material has a curl causing height detection sensors laser to read under the material. Fix the curl in the material or adjust sensors to read higher on sheet.

5.2.2.3 Cannot Feed Material

Issue: When attempting to feed materials, the suckers under the gantry do not make contact with the material or make contact, but do not pick material up.

Resolution #1:

Depending on material types and thickness, the height of the feeding table can adjusted by pressing the "UP" or "DOWN" button on the Eclipse.

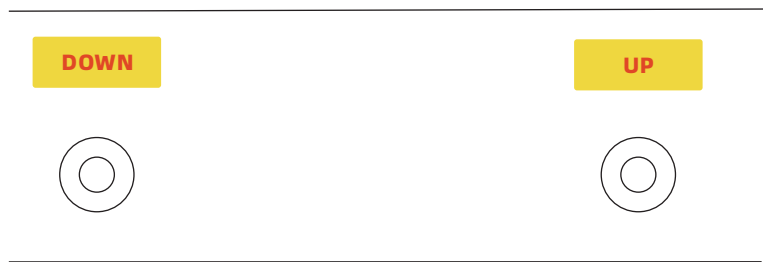

For air-impermeable materials, the loading table should be adjusted to the highest position. When the suction cup is grabbing the material, the suction cup should be in contact with the material.

For air-permeable materials, the height of the loading table should be appropriately lowered and distnaced between the suction cup and the material should be about 1-2mm.

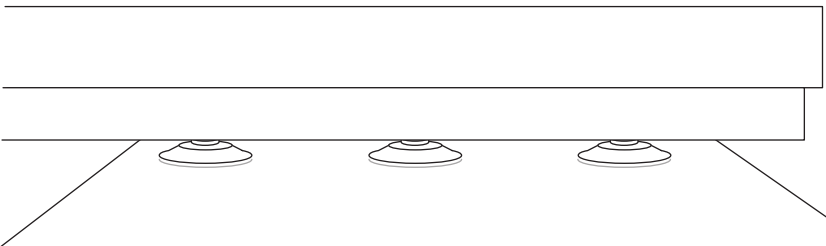

Resolution #2:

Curl in the material is causing height detection sensors to position material inaccurately.

Fix the curl in the material or adjust height sensors.

Resolution #3:

Vacuum pump is not working.

Check to ensure vacuum pump is powering on before feeding. Suction requires the vacuum pump to working in full power.

5.2.2.4 Material Sticks Together When Feeding

Issue: When attempting to feed materials, the suckers grab multiple sheets of material.

Resolution #1:

Align the material forward and fix the magnetic plates to hold material in place.

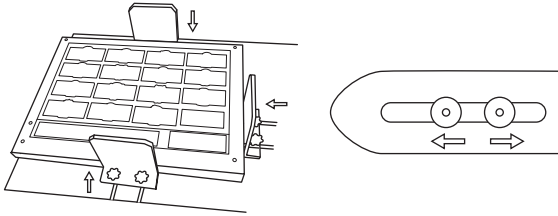

Adjust the length of the material separators to the proper position. The extension length is about 3-8mm.

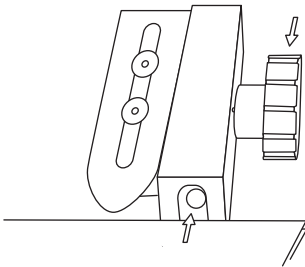

Resolution #2:

Adjust separator air power from solenoid.

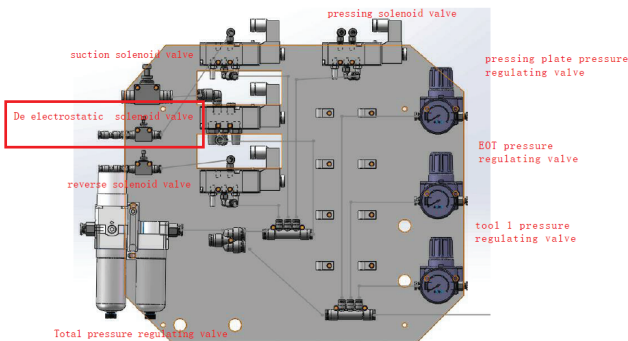

Open the thumb screen to increase air power.

Resolution #3:

Position loading device so material is beneath or in between the air separators. The ideal working height is for the air to separate materials and blow individual sheets upward to make contact with the sucker.

5.2.3 Cutting Issues

5.2.3.1 Edges Not Smooth

Issue: When cutting, edges are not smooth.

Resolution #1:

When using the DK tool, the blade will swivel in the chamber. Cut a short line before the turn, so the blade can change direction with the cut path.

5.2.3.2 Burrs on Cutting Edge

Issue: When cutting, the path of the cut will have burrs on the edges.

Resolution #1:

Adjust the length of the blade exposure from the DK tool.

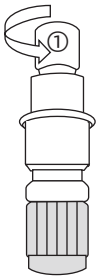

Half Cut

Adjust the length of the blade tip and try cutting on the material, as long as the material has been half cut to form a sticker, label etc.

Full Cut

Adjust the length of the blade tip and try cutting on the material, as long as the material has been cut through.

Resolution #2:

Blade could be broken, change blade out for a new one.

5.2.4 Conveyor Not Advancing After Cutting

Issue: After material is done processing, the conveyor is not moving to allow material to eject into collection device.

Resolution #1:

Check barometer and ensure it is set to at least 0.6MPa.

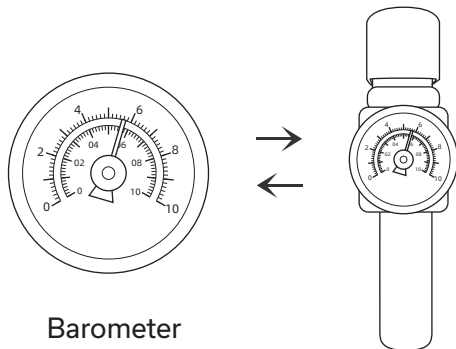

Resolution #2:

Adjust the tension of the belt by using allen keys. Depending on fixture, will require tightening or loosening.

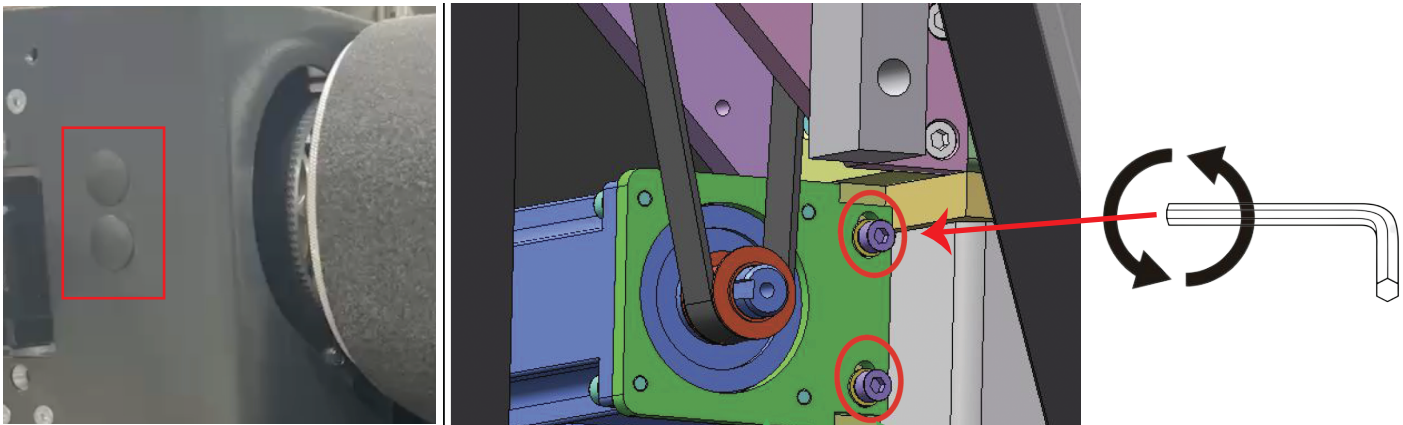

Remove covers to expose screw adjustments for belt tension. Insert an allen key and turn clockwise or counter clockwise dependent upon current status of belt tension.

If there is a lip in the belt near the front edge, tighten the belt by turning the allen key clockwise.

Be sure to adjust both sets of screws (4 total) evenly.

6. Maintenance

6.1 Maintenance Schedule

Maintenance Item	Method	Period	Related
Graphic blade holder clean	Check and clean debris inside blade holder	Every time before use	Depending by cut material
Check pressure valve and water level	Make sure pressure valve in normal condition, open tank to release water	Every day	Pic. E
Water separator	Make sure pressure is in accepted range, and check for water level	Every day	This water separator is with automatic water release (Pic. A)
Felt cleaning	Use air gun or vacuum cleaner	Every day	No sundries or bumps on surface
Lubricating oil in linear rail guide	Add lubricating oil for X,Y rail guide	Every six months	Pic.B
Lubricating oil in creasing tool axis	Add right amount of lubricant manually	Every six months	Pic.C
Lubricating oil in oscillating tool axis	Add right amount of lubricant manually, and inject grease in oil hole with oil gun	Every six months	Pic.D Pic.F

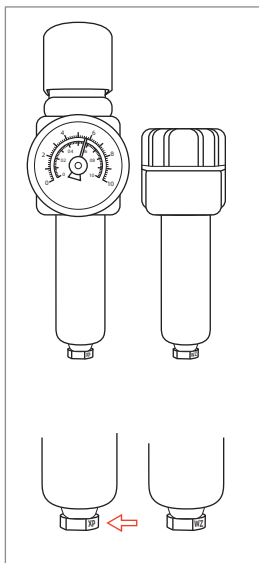

Pic.A

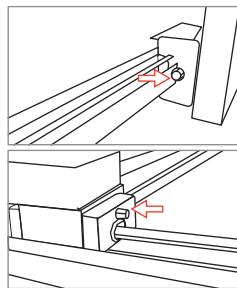

Pic.B

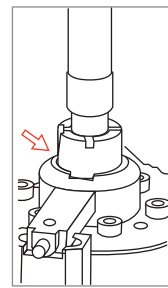

Pic.C

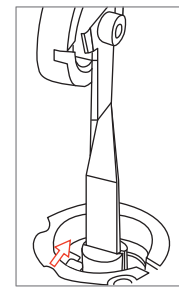

Pic.D

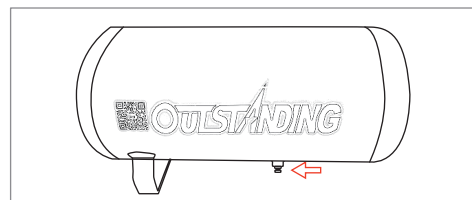

Pic.E

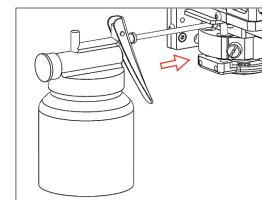

Pic.F

*Note: Lubricating oil, suggest use "Mobil 1 5W-30"; Lubricating grease, suggest use "Mobil grease MD"

6.2 Warranty

CUTWORX USA provides warranty replacement of parts and labor for a period of one year after completion of installation of a LST Series Digital Cutting Machine.

Response Times & Problem Resolutions

Calls placed into Post Sales Service Center are returned by a service technician within a twenty-four hour time period. Majority of software and hardware calls are diagnosed via remote support. Evening support is available upon request and availability.

Service Programs

CUTWORX USA offers a variety of service programs to match your requirements. Affordable support contracts are available as well as preventative maintenance. Remote support sessions are offered for new operator and follow up training. Personalized one on one sessions can be arranged in person or remotely with the Technology Center Specialist.

Other Services

Escalation Policy

The CUTWORX USA support team is a well-trained and highly qualified group of individuals. There is a support escalation policy in place in our CRM system. These escalation practices are implemented on a case-by-case basis in order to best serve the customer's needs.

Productivity Training and Consultancy

CUTWORX USA basic training courses teach your operators how to use all the functions of our system and can take place in our technology center. Material documentation, videos, and other resources are available to help assist. CUTWORX USA service team is focused on maximizing productivity for your machine.

About CUTWORX USA

CutworxUSA is a leader in finishing equipment with over 150 years combined experience in finishing solutions. We are committed to providing the best small and wide format finishing equipment, installation, service and training to increase your efficiency and productivity.

Our Workflow and Application Specialist can demonstrate our complete line of finishing equipment to validate it will meet your finishing requirements at our Technology Center in Irving, Texas.

Virtual demonstrates are now available upon request.

Copyright notice

Copyright 2022 CUTWORX USA.

This user manual can only be reproduced with the written authorization of CUTWORX USA. This regulation also applies to the excerpts of the manual. CUTWORX USA reserves the right to interpret the contents described in this user manual.

Trademark

The products, files, company names and logos listed in this user manual are registered trademarks of our company. December 2022



CUTWORX USA

8101 Tristar Dr STE 110
Irving, TX 75063

Email: sales@cutworxusa.com / support@cutworxusa.com
Website: www.cutworxusa.com